

RELATIONS BETWEEN CENTRIFUGAL BASKET DESIGNS AND MASSECUITE CHARACTERISTICS

by Dr. HELMUT EICHHORN
Salzgitter Maschinen AG

Introduction

Because of the variety of the massecuites produced during the manufacture of sugar, difficulties arise frequently in the course of the separation process. The design of centrifugal baskets must be adapted to such conditions.

The following paper, applying theoretical principles, published investigations and empirical values, deals with the design of centrifugal baskets, taking into consideration the massecuite characteristics and the conditions of technical procedure.

Massecuite Characteristics and their Utilization for the Basket Design

Important factors for the separation process, but also for the loading of centrifugal baskets, are size, form and uniformity of the crystals, the crystal content of the massecuite, as well as viscosity, surface tension, and composition of the syrup.

The separation process is essentially influenced by the centrifugal power

$$c = m \cdot r \cdot \omega^2$$

This equation shows that the radius affects the centrifugal power linearly, the angular velocity, however, squarely.

Some papers^{1 2 3} deal in detail with the influence of the centrifugal power with the separation process in case of various massecuites.

The centrifugal power has two important aspects in connection with basket design:

1. It influences the basket design under consideration of strength factors, viz. all forces due to gravity produced by the sugar layer, the syrup, the screens, and the weight of the basket casing, must be absorbed with multiple safety by the basket design.
2. The centrifugal power influences the basket form as well as the screen design under considerations of flow—which are decisive for the total pressure of the syrup flowing off.

Whereas the difference between the individual massecuite characteristics is of little importance for the factor mentioned under 1, the statement under 2 shows that different viscosity is decisive.

Generally, massecuites can be classified as follows:—

- (a) High-Grade Massecuites
- (b) High-Low-Grade Massecuites
- (c) Low-Grade Massecuites

(a) High-Grade Massecuites

These are refined or white sugar massecuites of high purity, the syrup of which has only a low viscosity of

about 50—200 cP. These massecuites can be easily cured, and at uniform crystal size they require low separating factors. White sugar massecuites having different crystal sizes (mixed crystals) complicate the separation process. For this reason centrifugal baskets of a centrifugal power of $c \geq 1100$ are mainly used for the massecuites.

The fact that these pure massecuites can be separated easily, complicates on the other hand a steady loading of the centrifugal baskets and requires suitable steps to prevent premature separation. We shall deal with this problem in detail later.

(b) High-Low-Grade Massecuites

The conditions during curing of high-low-grade massecuites whose sugar is dissolved again and added to a purer crystallization product, are more similar to those of white sugar massecuites, though the viscosity of syrup is higher by about 250 cP.

(c) Low-Grade Massecuites

During curing of low-grade massecuites the very fine crystal and the high viscosity of the syrup complicate the separation process. In this case you can count upon syrup viscosity values of about 60,000—70,000 cP. The centrifugal power should exceed $c \geq 1500$; in this connection reference is made also to Behne⁵, Antoine and Wiehe⁶, Eklund and Pratt⁷.

According to Tromp⁸, centrifugal powers of up to $c = 3000$ are used for low-grade massecuites.

On the one hand, the high viscosity complicates the separation process, on the other hand, however, it assists the loading process.

Centrifugal Basket Designs

The following deals in detail with the centrifugal baskets used in practice today.

Illustration 1 shows a basket with uniform holes covering the whole basket height. Baskets of this type with a horizontal plate as a charging device are frequently used. At the basket height of 800 mm low-grade and high-low-grade massecuites can be charged easily without separation of the massecuite at the loading zone of the basket wall.

In case of very pure massecuites containing large uniform crystals premature separation happens, partly due to the low viscosity of the syrup. This causes irregular charging and may result in rough running of the centrifugal.

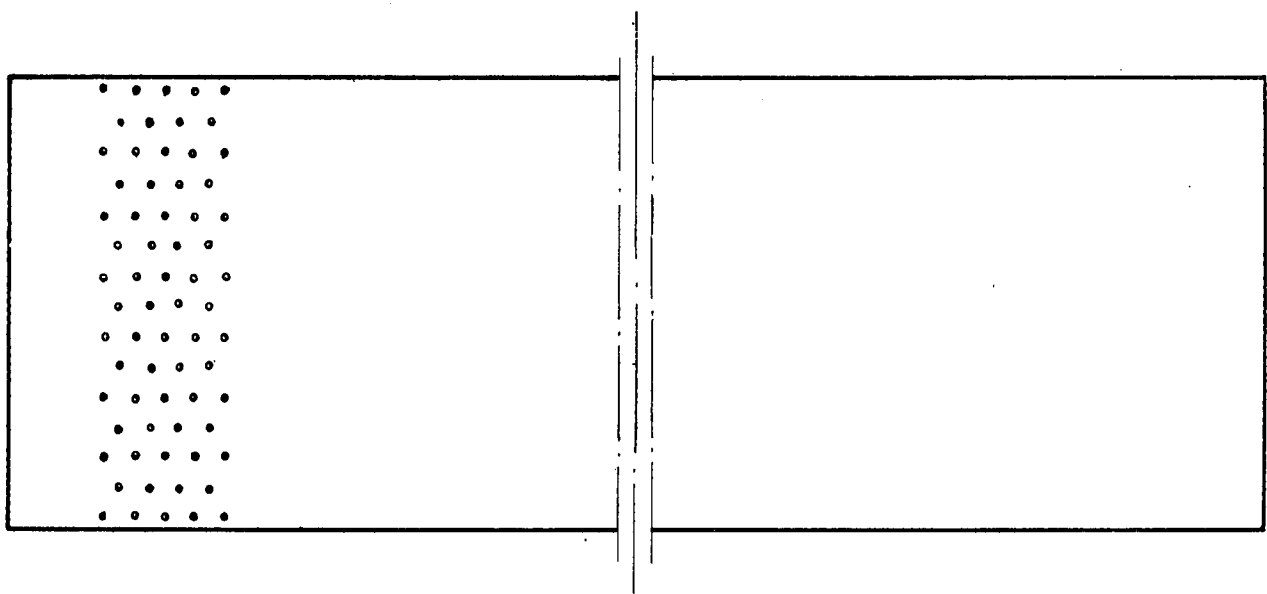
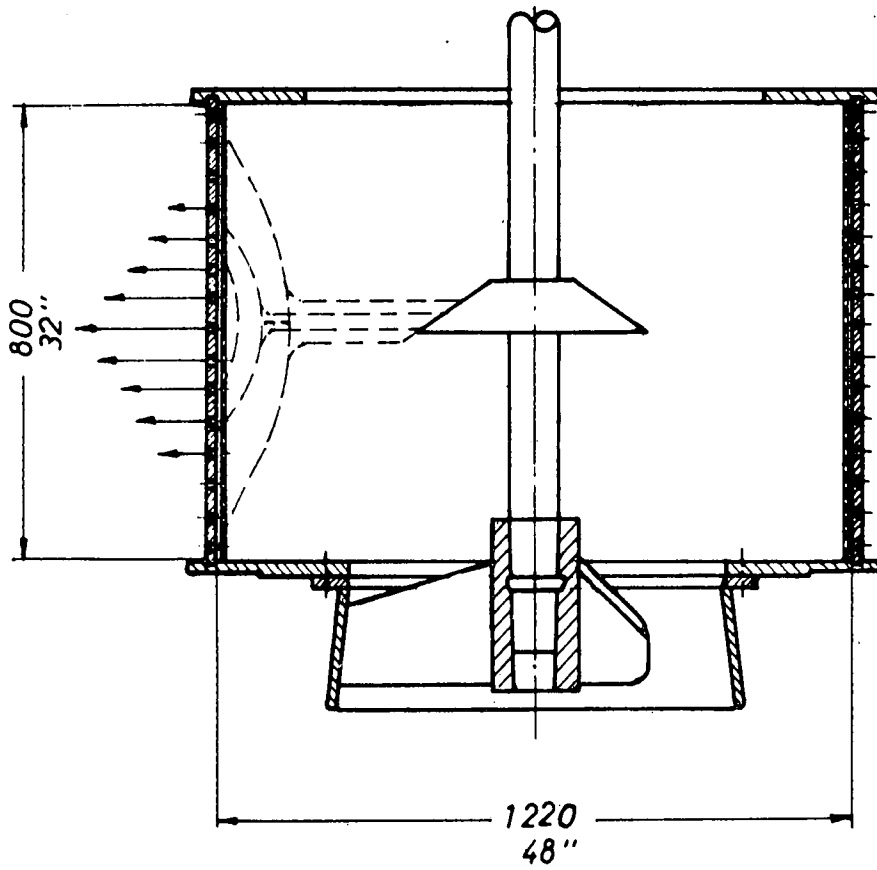

FIGURE 1: Usual baskets with equal perforation

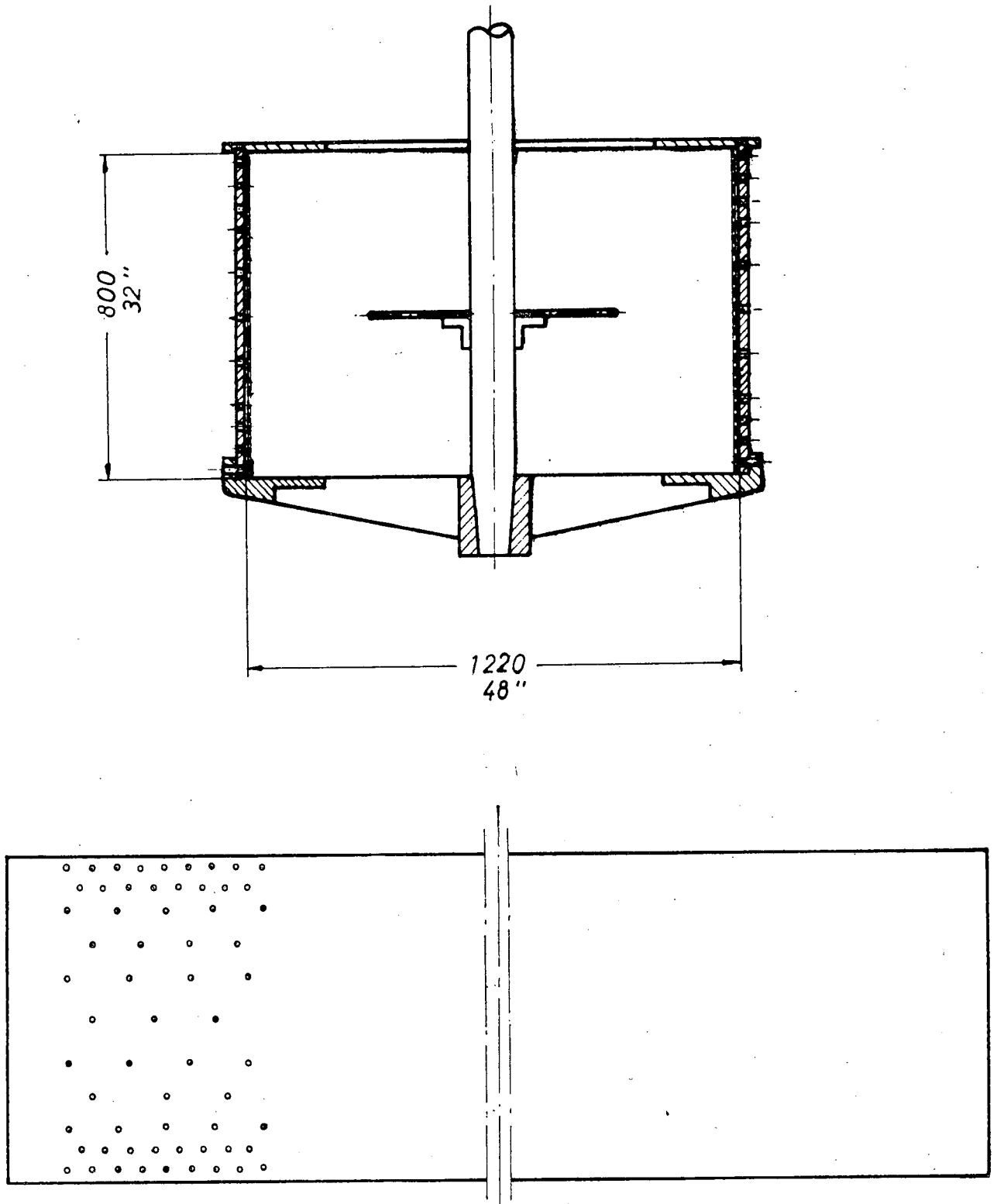

FIGURE 2: Basket with unequal perforation

Illustration 2 shows a similar basket provided with suitably arranged syrup discharge holes which prevent premature separation of the pure massecuites⁹. There are only a few discharge holes in the loading zone; their number increases, however, steadily in the direction of the basket cover and the bottom.

During the last few years centrifugals have been developed with larger units for charges of about 1000 kg of massecuite. When the centrifugal baskets were enlarged, the usual diameter of about 1200 mm was often maintained, and the basket height was extended to 1000 mm and more^{10, 11}.

Such a basket cannot be loaded with the plate charging method, even if the basket holes are made in accordance with illustration 2.

This results in the necessary substitution of a complicated charging method¹² in the place of the approved and simple plate device, as shown in illustration 3.

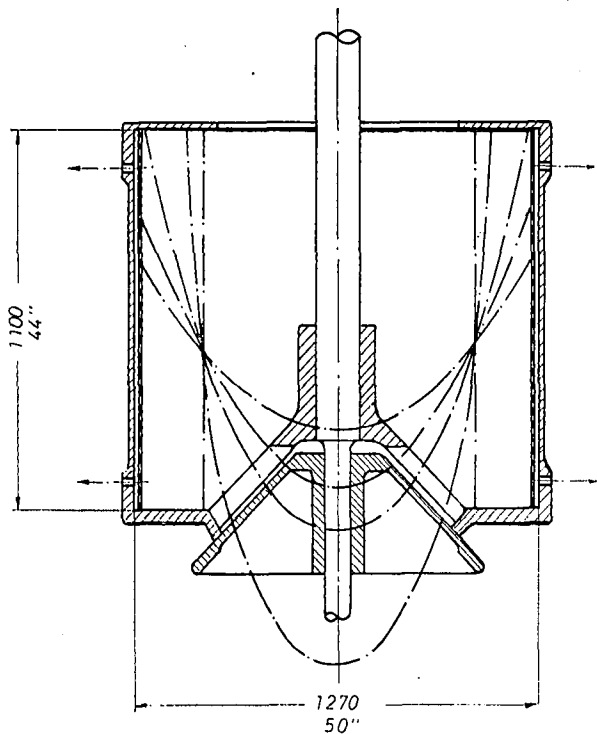

FIGURE 3: System of charging for a basket with holes in the wall only near the top and near the bottom

The perforation of the basket has been shifted to the top and bottom end of the casing¹³.

During loading the bottom of the basket is closed, and it is charged at about 50 r.p.m. After charging the centrifugal is accelerated, effecting the building up of the massecuite in a position parallel to the basket wall.

Besides this complication, the disadvantage of the method is an extended charging time; Höhne¹⁴ gives charging times of an average of 23 seconds.

Because of the problems of the charging procedure a high centrifugal basket was developed which prevents premature separation even in the case of high-

purity massecuites. Thus the centrifugal basket can be charged by means of the simple plate device.

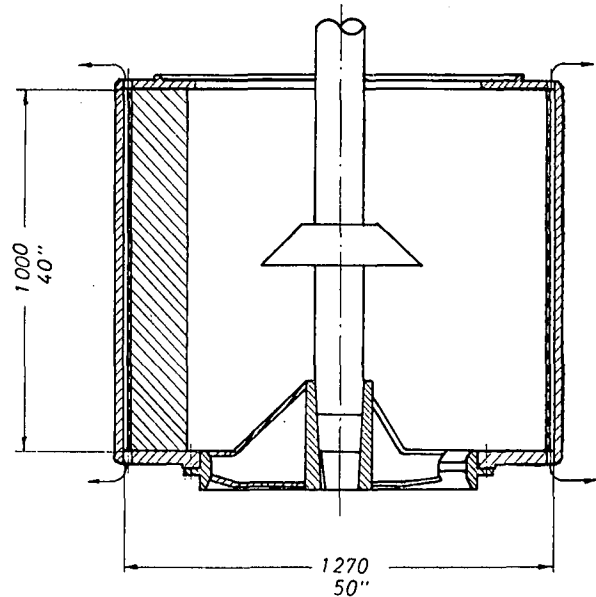

FIGURE 4: Basket without any holes in the wall, holes only on the top and in the bottom

Illustration 4 shows this basket with openings for the passage of the syrup only in the cover and the bottom. Accordingly the syrup must cover the longest possible distance in the basket¹⁵.

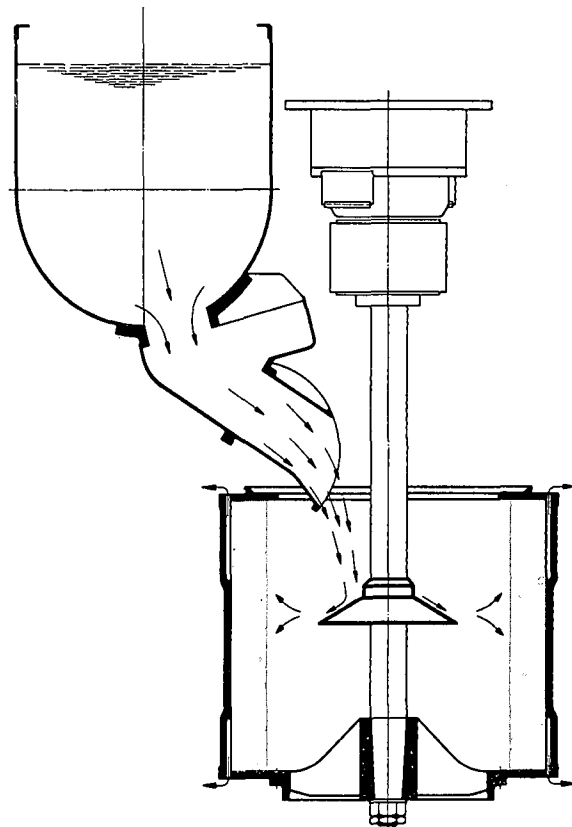

FIGURE 5: Method of operation of the unperforated basket with the plate system of filling

No syrup can flow from the massecuite striking the impermeable basket wall, i.e. the syrup remains with the crystals, in this way the massecuite maintains its fluidity. Thus the massecuite flows equally to the top and to the bottom. The number of holes in cover and bottom is limited in such a way that there is a delay in the discharge of the syrup.

Practice has shown the theoretical considerations to be correct. The co-ordination of the above mentioned features — basket wall without holes, and a certain number of holes in cover and bottom — effects a satisfactory filling of the basket by means of the plate filling system which is shown in Fig. 5. The basket can be charged satisfactorily even with coarse-grained refined massecuites.

This simple filling system has been maintained for a high basket. Another advantage of the system is its short filling time. It takes about 10 seconds to fill the basket at 200 r.p.m.

Flow Considerations of the Centrifugal Basket without Holes in the Shell

In the previous sections the suitability of a centrifugal with an unperforated shell was explained. Now the theoretical operating principles of such a basket are described.

1. Survey of Quantities

For calculation of the necessary free axial sections of the discharge zone as well as of the syrup discharge holes, it is necessary to know the quantities of syrup to be discharged.

During the charging process part of the syrup will be spun off. The fluidity of the massecuite, however, must be maintained during the whole charging process to assure correct filling. So only a quantity of syrup "Q Syrup Max" may be discharged during the charging period, which must not exceed 10 seconds.

The charge of the basket is 1200 kg. of massecuite. The supposed syrup-crystal ratio is 600 : 600. The limit of fluidity of the massecuite is achieved when the free spaces in the aggregation of crystals are filled by syrup and an additional 10% of the free syrup is available.

$$600 \text{ kg of crystallite aggregation } (\gamma_1 = 1.0) V = \frac{G}{\gamma_1} = \frac{600}{1} = 600 \text{ l of aggregation of crystals.}$$

$$600 \text{ kg of crystals } (\gamma_2 = 1.6) V = \frac{G}{\gamma_2} = \frac{600}{1.6} = 375 \text{ l of volume of crystals.}$$

So there will result the free space of 600 — 375 = 225 l in the crystallite aggregation.

The free space is filled by syrup of $\gamma = 1.35$. The weight is calculated as follows:

$$g = V \cdot \gamma = 225 \cdot 1.35 = 304 \text{ kg of syrup} \\ + 10\% = 30.4 \text{ kg of free syrup} \\ \underline{\hspace{10em}} \\ 334.4 \text{ kg of syrup}$$

600 kg of crystals + 334.4 kg of syrup results in 934.4 kg of flowable massecuite.

From the difference of 1200 kg of massecuite, basket load — 934.4 kg of flowable massecuite, the maximum syrup quantity which may be separated during loading results. "Q Syrup Max." = 265.6 kg.

It is assumed that the syrup quantity "Q Syrup Max." is produced equally over the whole basket height of 1000 mm.

As evidence that there is no separation of massecuite in the basket during the charging procedure, the calculation of the actual flow speed of the syrup in a basket approved in practice shall be sufficient. A comparison of the actual flow speed shows the filling quality of the massecuite in the basket.

2. Maximum Syrup Flow Speed in the discharge Holes in the bottom and the cover of the basket.

The quantity of syrup which may be discharged in the whole basket is 265.6 kg/10 sec. = 26.6 kg/sec

The free cross section of the syrup discharge holes in cover and bottom is $F = 42 \text{ cm}^2$.

The flowing syrup volume is

$$V = \frac{G}{\gamma} = \frac{26.6}{1.35} = 19.7 \text{ l/sec.} = 19700 \text{ cm}^3/\text{sec.}$$

So the maximum flow speed is

$$v_{\text{max}} = \frac{V}{F} = \frac{19700}{42} = 470 \frac{\text{cm}}{\text{sec}} = 4.70 \frac{\text{m}}{\text{sec}}$$

3. Actual Syrup Flow Speed in the Discharge Holes

The calculation of the actual Syrup Flow Speed is based on the fluid pressure of the syrup layer which results from the centrifugal force at a speed of 200 r.p.m. and the syrup layer thickness of 8 mm.

The following data of a refined syrup were taken as a basis:

$$\begin{aligned} \text{Solids } Bx &= 73.7^\circ \\ \text{Temperature } t &= 60.5^\circ\text{C} \\ \text{Viscosity } \eta &= 67 \text{ cP } (1 \text{ cP} = 1.02 \cdot 10^{-4}) \\ &\quad \frac{\text{kg} \cdot \text{sec}}{\text{m}^2} \end{aligned}$$

For the estimation of the flow the Reynold's Number is important.

$$Re = \frac{v \cdot a \cdot \rho}{\eta}$$

The diameter of the syrup discharge holes is 7 mm, their length 15 mm.

For the calculation of the Reynold's Number the maximum syrup speed of $v = 4.7 \frac{\text{m}}{\text{sec}}$ is taken as basis first.

$$Re = \frac{v \cdot a \cdot \rho}{\eta} = \frac{4.7 \times 7 \times 1.35 \times 10^3 \times 10^4}{67 \times 1.02 \times 9.81} = 660$$

The value of the Reynold's Number shows that the flow in the syrup discharge holes is laminar.

The fluid pressure is calculated:

$$P = \frac{m \cdot r \cdot \omega^2}{F_1}$$

$$P = \frac{G \cdot v \cdot \left(\frac{\pi n}{30}\right)^2}{g \cdot F_1}$$

$$P = \frac{F_1 \cdot h \cdot \gamma \cdot r \cdot n^2 \cdot \pi^2}{g \cdot F_1 \cdot 30^2}$$

$$= \frac{1 \times 0.008 \times 1350 \times 0.630 \times 200^2 \times \pi^2}{9.81 \times 1 \times 900}$$

$$P = 306 \frac{\text{kg}}{\text{m}^2}$$

The formula for the fluid pressure and the flow speed under consideration of a pipe friction and body resistance is:

$$P = \gamma \frac{v^2}{2g} \left(1 + \lambda \frac{l}{d} + \zeta_E\right) \dots \dots \dots (1)$$

λ is a dimensionless factor depending only on the Reynold figure and the roughness.

In the laminar flow range is

$$\lambda_{\text{lam}} = \frac{64}{\text{Re}} = \frac{64}{660} = 0.097$$

The resistance coefficient ζ_E takes into consideration an entrance shock loss of the flow into the syrup discharge holes and can be put with sufficient accuracy $\zeta_E = 0.5$.

By transformation of the equation (1) the flow speed results

$$v = \sqrt{\frac{P}{\gamma \left(1 + \lambda \frac{l}{d} + \zeta_E\right)}}$$

$$= \sqrt{\frac{306 \cdot 2 \cdot 9.81}{1350 \left(1 + 0.097 \left(\frac{15}{7}\right) + 0.5\right)}}$$

$$v = \sqrt{2.61} = 1.61 \frac{\text{m}}{\text{sec}}$$

The speed must be considered as approximate since for its calculation the Reynold's Number was taken for too high a speed. In another approximate value the result will be corrected. The Reynold's Number will be defined instead from the speed ratio before and after the first calculation.

$$\text{Re}_1 = \text{Re} \frac{v}{v_{\text{max}}} = 660 \frac{1.61}{4.7} = 226$$

then is:

$$\lambda_{\text{lam}_1} = \frac{64}{\text{Re}_1} = \frac{64}{226} = 0.283$$

and then:

$$V_1 = \sqrt{\frac{P \cdot 2g}{\gamma \left(1 + \lambda_1 \frac{l}{d} + \zeta_E\right)}}$$

$$= \sqrt{\frac{306 \cdot 2 \cdot 9.81}{1350 \left(1 + 0.283 \left(\frac{15}{7}\right) + 0.5\right)}}$$

$$V_1 = \sqrt{2.5} = 1.5 \frac{\text{m}}{\text{sec}}$$

So the actual speed in the syrup discharge holes is

$$\underline{\underline{1.58 \frac{\text{m}}{\text{sec}}}}$$

4. Utilization of Results

In accordance with the calculation shown under 3 the syrup flow speeds are calculated for the whole charging period. The curve resulting from this is shown in Fig. 6.

A speed is taken for maximum flow speed where just so much syrup can flow off that the fluidity of the masseците can be maintained.

At the beginning of the charge period the actual flow speed has the value ZERO and then increases in accordance with the increasing fluid pressure caused by the increasing strength of the syrup layer during the charging operation.

The surfaces below the curves are proportional to the quantity of syrup just flowing off.

The surface below the curve for the actual speeds is smaller than the surface limited by the medium maximum speed. This means that at the end of the filling procedure the masseците is still fluid; assuring an equal distribution of the masseците in the basket.

After the charging is completed, the speed of the basket is increased, which will raise the fluid pressure materially.

The deceleration occurring as a result of the charging of the basket is counteracted by increasing the speed. This assures a quick discharge of the syrup.

It was found possible to charge 1200 kg of masseците into a basket designed for 1000 kg only.

Applied Abbreviations and Formula Symbols

c = centrifugal force	kg
m = mass	$\text{kg} \frac{\text{m}}{\text{sec}^2}$
r = radius	m
ω = angular velocity	sec^{-1}
V = volume	$\text{dm}^3 = 1$
G = weight	kg
γ = specific gravity	$\frac{\text{kg}}{\text{dm}^3}$
V = speed	$\frac{\text{m}}{\text{sec}}$
Bx = solids	%
t = temperature	°C

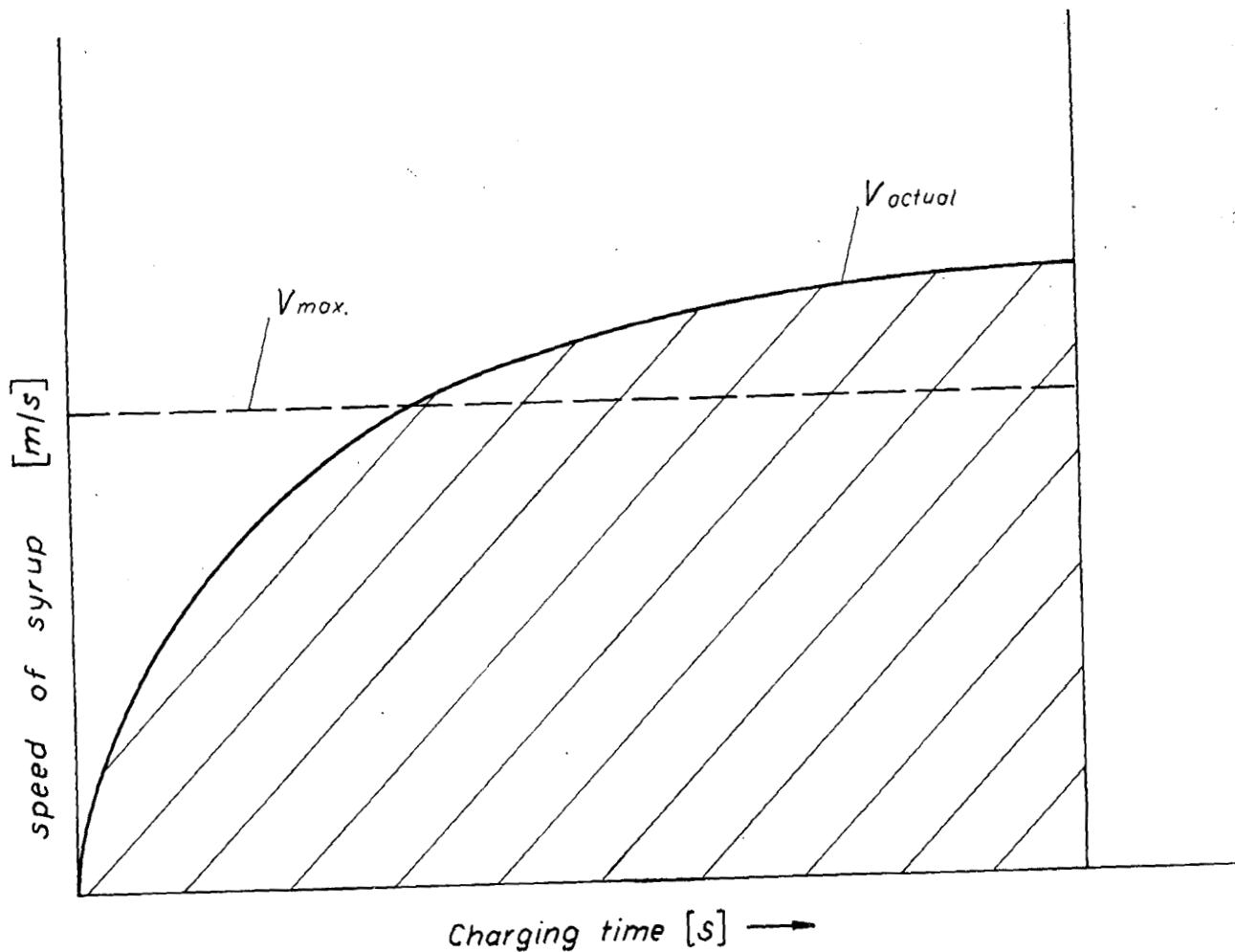

FIGURE 6

ρ = density	$\frac{\text{kg} \cdot \text{sec}^2}{\text{m}^4}$
η = viscosity	$\frac{\text{kg} \cdot \text{sec}}{\text{m}^2}$
Re = Reynold figure	1
P = fluid pressure	$\frac{\text{kg}}{\text{m}^2}$
F = surface	m^2
g = acceleration due to gravity	$\frac{\text{m}}{\text{sec}^2}$
n = speed	min^{-1}
λ = resistance coefficient	1
ζE = resistance coefficient	1
l = length	mm
d = diameter	mm

Summary

By means of diagrams the loading potential of various types of centrifugal baskets is compared.

Utilizing different perforations of the basket shell, an endeavour is made to cater for various qualities of the massecuites.

It is difficult to load these baskets with the plate loading method in the case of very pure massecuites whose syrup has low viscosity.

A basket design is described whose shell is not perforated. The syrup is discharged through holes in the cover and the bottom. The theory of filling of this basket is described in detail.

It is shown that this basket can be loaded with the simple plate filling method.

References

1. Magnusson, O. High efficiency centrifugals. Socker 5 (1949), 65-95.
2. Kiessling, C. High efficiency centrifugals for the sugar industry. Socker 8 (1952), 53-69.
3. Eichhorn, H. Über das Trennen von Kristall-Sirup-Gemischen mit Zentrifugen Zeitschr. f. d. Zuckerindustrie 16 (1966), 463-468.
4. Stevens, G. E. Advantages of high-speed centrifugals. Int. Sugar J. 52 (1950), 9.
5. Behne, E. R. Separation of molasses from the sugar crystals in centrifugals. Techn. Comm. B.S.E.S. Queensland 1938, Nr. 8, ref. Int. S. J. 41 (1939), 283.
6. Antoine, J. D. de Saint and Wiehe, F. Untersuchungsergebnisse beim Schleudern von Nachprodukt-Füllmassen in hochoberigen Zentrifugen Zeitschr. Zuckerind. 13 (1963), 511-514.

7. Eklund, W. N. and Pratt, J. H. Drying low grade sugar at higher speeds. *Facts about Sugar*, 30 (1935), 95-96.
8. Tromp, L. A. High-speed centrifugals. *Int. Sugar J.* 54 (1952), 159
9. D.A.S. 1 120 378. Diskontinuierlich arbeitende Trennzentrifuge für kristallhaltige Füllmassen. Selwig u. Lange.
10. Pause, K. Die Zentrifugenentwicklung am Scheidewege. *Zeitschr. f. d. Zuckerind.* 13 (1963), 138-141.
11. Eichhorn, H. The Salzgitter 1000 kg-centrifugal Salzgitter Machinery Technical Bulletin. 1966, No. 2.
12. Pause, K. Über das Füllen laufender Pendelzentrifugen mit Zuckerfüllmassen. *Zeitschr. f. d. Zuckerind.* 5 (1960), 238-243.
13. DGBM 1 865 091. Großtrommel für Zuckerzentrifuge Buckau-R. Wolf.
14. Hohne, K. Vergleich von drei diskontinuierlichen vollautomatischen Weißzucker-Zentrifugen. Diplomarbeit, Techn. Universität Berlin, 1964.
15. D.A.S. 1 209 957. Vollmantel-Schleudertrommel. Salzgitter Maschinen AG.

Discussion

Mr. Chiazari: It is generally thought that low-speed pre-curing has certain advantages, chiefly because it increases basket capacity.

Holes in the top of the basket should be of assistance in curing low grade sugars, especially if they are false grained.

Mr. Dent: How are the screens fixed in this type of basket so as to avoid leakage?

Dr. Eichhorn: There are three screens in the big basket, and they are secured by rings at the top and the bottom.

Mr. Renton: We had a problem in charging B-masseccutes at Darnall. If we did not reduce the charging rate when the masseccuite was slack a surge occurred in the basket which unbalanced the centrifuge. Apparently the masseccuite was not consolidating itself while being charged and the way to correct this was by reducing the charging rate. Would Dr. Eichhorn recommend the Salzgitter basket for the type of B-masseccuite we have in this country?

Dr. Eichhorn: We have charged the basket with three types of masseccuite—refined sugar, B- and C-.

Leakage has been prevented by running the centrifugal at 1,000 revolutions per minute for about three minutes and then increasing the speed.

With coarse-grained crystals in refined sugar masseccutes it is sometimes difficult to get a parallel layer of sugar in the basket but this centrifuge copes well with this, and also with B-masseccutes.

Dr. Douwes Dekker: What is the maximum viscosity of syrup that this type of basket can deal with? In the beet sugar industry viscosities are lower than in the cane sugar industry.

Dr. Eichhorn: We have tested viscosities of from 300 to 400 cP. For a C-masseccuite the basket needs holes in the wall in addition to those in the top and bottom.