

HYPERTHERMOPHILIC BACTERIAL ACTIVITY DURING CLARIFICATION

By MISS L. M. BROOKSTEIN

Hulets Sugar Limited, Mount Edgecombe

Abstract

Examination of clarifier juices and muds has established the presence of hyperthermophilic micro-organisms which are capable of metabolising carbohydrates. The measurement of the level of lactic acid, a metabolic by-product, is indicative of the amount of sucrose destruction. Increased retention time of juice and mud, and temperature reduction increase the extent of the deterioration occurring.

Introduction

It has hitherto been assumed that the high temperatures found in clarifiers (subsiders) will inhibit or even terminate microbial activity. Research into life at high temperatures has established the survival and growth of micro-organisms in hot springs¹ at temperatures approaching 95°C. Hot springs are low in organic matter² whereas the clarifiers have a continual source of sucrose and other nutrients available. Microscopic examination of Mount Edgecombe clarifier juice and muds has confirmed the presence of micro-organisms.

Thermophiles are capable of growth above 55°C,³ and because of the extreme environment are very highly adapted. Their enzymes are heat stable,¹ and can catalyse reactions despite the high temperatures. Thus normal cellular growth and metabolism can continue. In addition micro-organisms that have lower temperature optimums will form spores and will remain dormant until the temperature falls to more suitable levels, when they will germinate and resume activity.

A generalised growth curve may be applied to the microbial culture in the clarifier.

There is an initial lag phase, while the micro-organisms adapt to the change in environment, during which time the growth rate is zero. Exponential growth is then attained but only till a maximum value is reached, after which the culture enters the stationary phase. The death phase follows, with a negative growth rate. In high temperature systems there is often a very high death rate,⁴ but it is normally offset by a marked exponential growth rate.

The clarifier is a continuous system, with the introduction of limed juice and the removal of clear juice and mud.

The mixed juice has a large heterogeneous population of micro-organisms^{5,6}. The majority of these are mesophiles which will be unable to survive in the extreme conditions and will either be destroyed or will sporulate. The remaining number, after a lag period (See Fig. 1), enter the rapid growth phase. The retention time and flow characteristics of the juice and mud in the clarifier determine the overall extent of the hyperthermophilic growth and activity.

The microbial destruction of sucrose within clarifiers, as in diffusers, results in the production of various by-products.⁷ Lactic acid is one of the principal organic acids formed,⁸ and provides a means of monitoring microbial activity. It has been reported by Oldfield et al⁷ that there is a ratio between sucrose lost and lactic acid formed. An average ratio of 2 parts sucrose to 1 part lactic acid is accepted. Use of the ratio yields an estimate of sucrose loss as a consequence of microbiological activity.

Over a period of two seasons, the microbial and lactic acid content of clarifier juice and mud were monitored at Mount Edgecombe to establish the extent of deterioration during normal operating conditions and over weekend stops. In addition, laboratory experiments were conducted to confirm the results obtained from the mill composite samples.

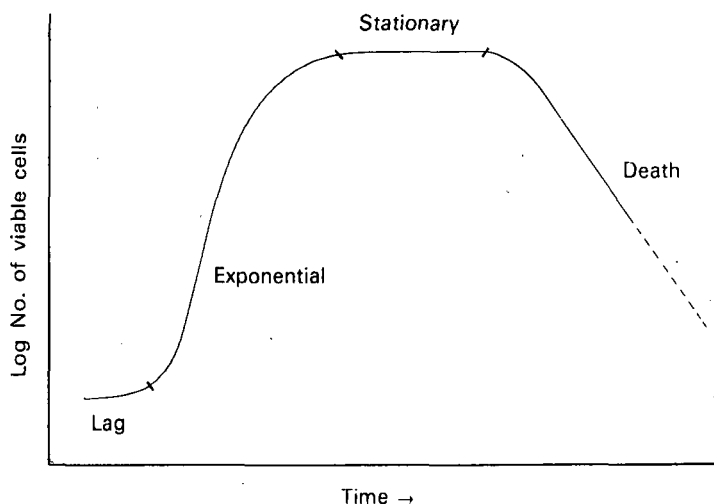

Figure 1:

Experimental procedure

Determination of total microbial count –

Catch samples of mixed juice, clear juice, mud and filtrate return were aseptically collected. Suitable dilutions were performed in 1% sterile saline, and a 1 ml aliquot of the final dilution was pour plated in cane juice agar. The mixed juice plates at pH 5,5 were incubated at 30°C while the clear juice, mud and filtrate return plates at pH 7,0 were incubated at 68°C.

Anaerobic counts were performed as above, but were incubated in a Gallenkamp anaerobic jar and either flushed with a CO₂/N₂ gas mixture or a BBL gaspack was used.

Determination of the spore count –

A 100 ml aliquot of mixed juice was aseptically transferred to a sterile Erlenmeyer flask, and boiled for 10 minutes. The contents were then remade to the 100 ml mark with sterile distilled water. Suitable dilutions were performed in 1% sterile saline and spread plated on Dextrose tryptone agar. The plates were incubated at 45°, 55° and 65°C for 48 hours.

Lactic acid analysis –

All juice and mud samples after collection were preserved with Mercuric chloride and kept chilled until analysed. A sub-sample was filtered through Whatman No. 42 paper and 25 ml of the filtrate were used for the ion-exchange. The method then followed was that of Oldfield and Shore (1970)⁹ as modified by McMaster and Ravnö (1977)⁶

Laboratory deterioration experiments –

- a) 1) Sterile filtered mixed juice was equilibrated in a water bath at 80° – 87°C. A 5 ml portion of clarifier mud or filtrate return was then added and incubated for 24 hours at the set temperature.
- 2) 1 litre of clarifier mud or mixed juice was aseptically dispensed into 2 sterile flasks. One flask was preserved as the control, the other was incubated in a water bath at 80° – 87°C for 24 hours.
- b) In both cases the sample and the sterile control were analysed for sucrose, reducing sugars and lactic acid.

Results and Discussion

Types of Micro-organisms present -

From clarifier mud and clear juice a number of bacterial strains have been isolated, the majority of which belong to the spore forming genus *Bacillus*.

All are hyperthermophiles³ and have optimum growth temperatures from 70° to 85°C and will not grow below 50° to 55°C. Many are facultative anaerobes (See Table 1), a necessary adaption, since juice and muds have low oxygen contents and the flashing of the limed juice removes all air.

Preliminary identification of these strains has indicated that strains of *B. coagulans*, *B. stearothermophilus*¹¹ and *B. megaterium* are present.

A thermophilic Actinomyces¹⁰ has also been isolated and cultured from the clarifiers. A small coccobacillus that resembles *Leuconostoc* has been isolated from the muds. A similar observation is recorded by Bevan and Bond.¹² This micro-organism has similar biochemical characteristics, cellular shape and size, and typical mucoid colony morphology to *Leuconostoc* strains. It also produces a polysaccharide-like slime and does not form spores. It differs from *Leuconostoc* in its ability to survive high temperatures and has been cultured on sucrose tryptone agar at 55°C and 65°C in the laboratory.

Normal clarifier operating conditions-

Micro-organisms in clarifiers originate from two sources. The input of mixed juice and filtrate return into the clarifiers is the first; and the second is the normal thermophilic population within clarifier juice and mud.

Mixed juice has a high bacterial content, but the majority of these micro-organisms are mesophiles⁶ and will be unable to survive in the clarifier.

Fig. 7 shows that with increasing incubation temperature there is a decrease in the mixed juice bacterial titre. It was also established that thermophiles in mixed juice are initially present as spores which, on exposure to sufficiently high temperatures and nutrients, will germinate and resume metabolic activity.

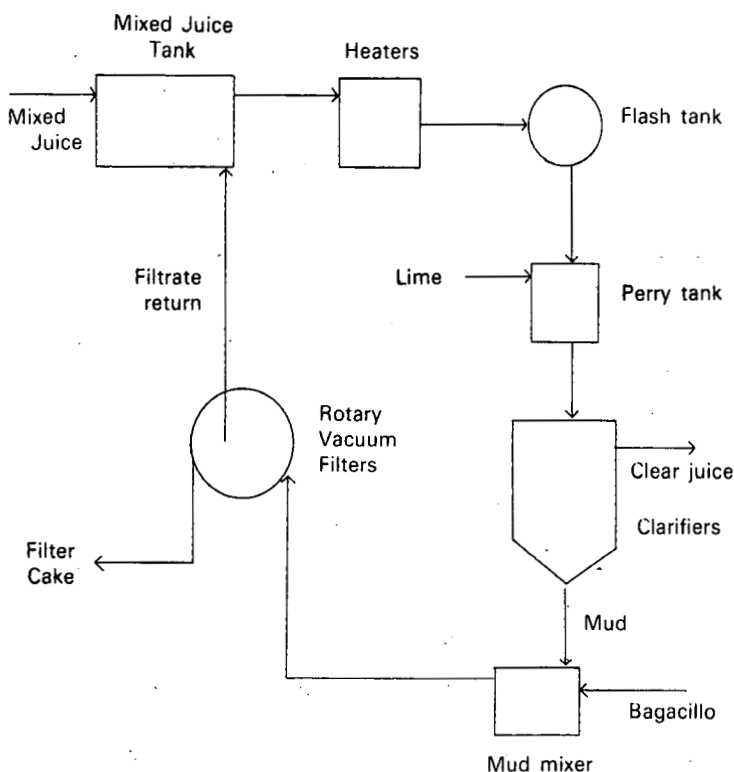

Figure 2: Schematic flow diagram



Figure 3: Bacteria in a catch sample of clear juice. Note the pairs of rods (arrowed)

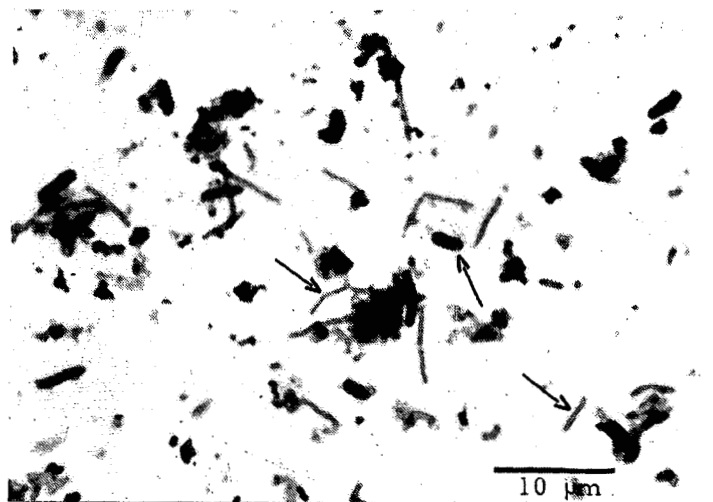

Figure 4: Bacteria (arrowed) in a mud sample.

TABLE I
Mean total viable count/ml

Season \ Sample	Incubation	Mixed juice	Clear juice	Mud	Filtrate return
1976/77	Aerobic	2, 1 x 10 ⁶	32	1, 2 x 10 ³	n.d.
1977/78	Aerobic	9, 1 x 10 ⁶	23	1, 1 x 10 ³	2, 8 x 10 ⁴
	Anaerobic	n.d.	2	3, 5 x 10 ²	n.d.

n.d. = not determined.

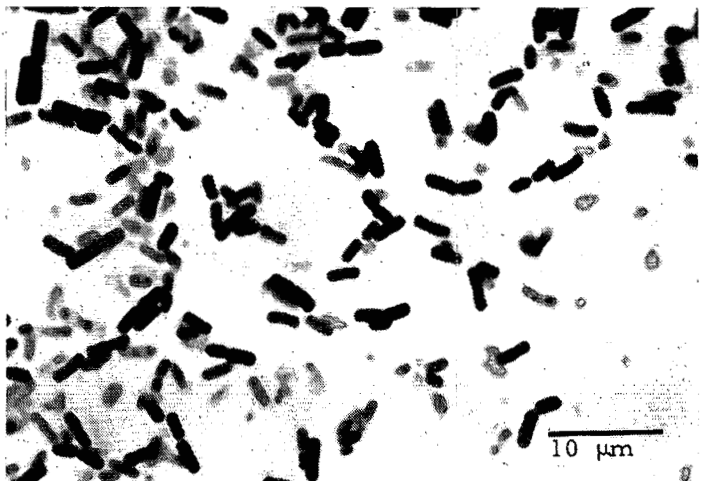

Figure 5: Gram stain of a *Bacillus* species isolated from the mud.

Filtrate return recycles micro-organisms that have been removed from the clarifier via the muds. These micro-organisms have already adapted to clarifier conditions. The heating and liming of the mixed juice will destroy viable micro-organisms, but those in the dormant spore stage will survive.

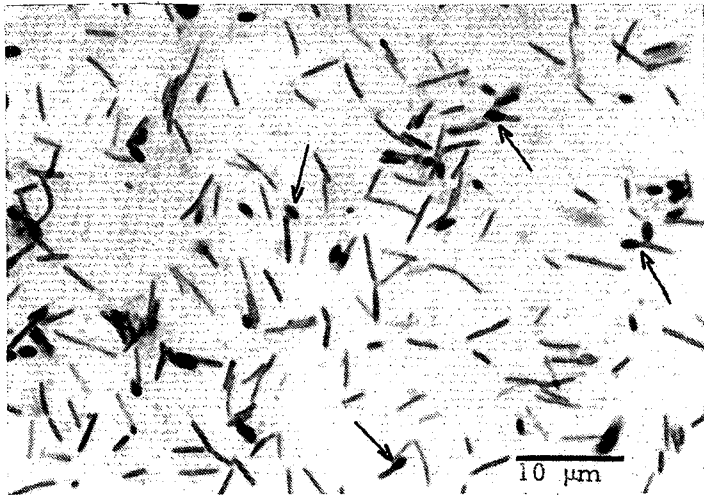

Figure 6: Spore stain of a *Bacillus* species cultured from the mud. Arrows indicate some of the stained spores.

Within the clarifier, the micro-organisms distribute between the clear juice and mud. Clear juice typically has a low total count (see Table 1). The sedimentation of suspended matter removes micro-organisms from the juice into the muds. The short residence time of the juice also restricts excessive

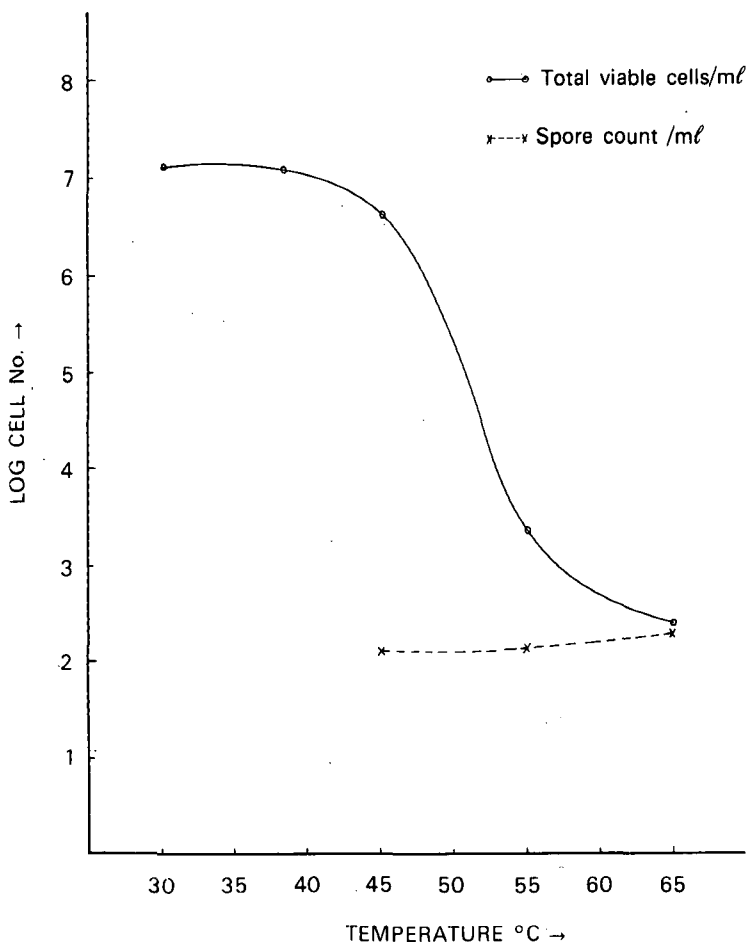

Figure 7: The effect of temperature on micro-organisms in mixed juice.

microbial growth. The lactic acid levels of clear juice show an increase from mixed juice.

Statistical tests have shown a significant difference between the two sets of results (mixed juice, clear juice). This increase is generally small, and can be attributed to filtrate return. The lactic acid level in filtrate return inflates that of clear juice.

Clarifier muds have a high thermophilic bacterial count due primarily to a concentration of micro-organisms from clear juice, and to the subsequent growth in the muds. (See Table 1) The microbial growth is stimulated by uneven high temperature distribution through the muds.¹³ The lactic acid content of clarifier mud is higher than that of clear juice because of this microbial activity. (See Table 2)

TABLE 2
Mean lactic acid levels/ppm on °brix.

Sample	Mixed juice at the scales	Clear juice	Mud	Filtrate return
Season				
1976/77	650	675	800	2 075
1977/78	880	935	1 105	1 700

On filtration of the muds the lactic acid content and the microbial population are transferred to filtrate return. The filter station, having a less severe environment than the clarifier, promotes extensive microbial activity. There is thus a large increase in the lactic acid level from mud to filtrate return. There is a good linear correlation between lactic acid in mud and filtrate return. The condition of the muds directly influences that of filtrate return.

To summarise, under normal operating conditions retention time is minimal, restricting the time available for the microbial population to cause serious sucrose loss. The constraints of temperature,¹ pH and oxygen levels all prevent extensive microbial growth and maintain the small thermophilic population at a constant level.

Prolonged residence time in clarifiers -

1) One versus two clarifiers

When additional clarifier capacity is used for juice clarification the average retention of the juice and muds increases. The effect of residence time was monitored in a comparison between one and two clarifier operation at Mount Edgcombe.

Results obtained from a short trial indicate that there is a significant difference between the two modes of operation. With two clarifier operation there was an improvement in clear juice quality which can be attributed to better settling of suspended solids. However with increased retention time there was more microbiological deterioration of the juice, mud and filtrate return.

Microbial levels showed a marked increase in muds and filtrate return from one to two clarifier operation. As a consequence there was an increase in lactic acid.

The levels of lactic acid clearly demonstrate that more thermophilic degradation of sucrose is occurring with two clarifier operation. All microbial and lactic levels returned to their former low values after the second clarifier had been liquidated and taken off line.

Thus residence time directly influences both microbial and lactic acid levels.

2) Mill stops

Over a weekend stop the clarifiers remain full and sucrose

deterioration can be significant, with consequent purity drops.¹³ Muds were monitored to establish the extent of the deterioration occurring.

TABLE 3

Mean total microbial count/m^l for the one versus two clarifier trial.

No. of Clarifiers \ Sample	Clear Juice	Mud	Filtrate return
One	7	50	1, 21 x 10 ³
Two	9	100	7, 0 x 10 ³
One	6	62	2, 13 x 10 ³

TABLE 4

Mean lactic acid levels/ppm on °brix for the one versus two clarifier trial.

No. of Clarifiers \ Sample	Clear juice	Mud	Filtrate return
One	540	615	975
Two	925	1 020	1 710
One	645	695	1 110

Lactic acid levels increased, on average, by 38% (see Table 5) over the shutdown. During the sixteen hours residence temperatures drop to 80° - 85°C. A good linear correlation between lactic acid increase and temperature drop has been found. The lower temperatures stimulate hypothermophilic activity with subsequent lactic acid formation. There is a poor correlation between lactic acid increase and purity loss. This indicates that other factors e.g. chemical inversion are contributing to the drop in purity.

Similar trends were observed for short unplanned stops e.g. due to lack of cane. Sucrose degradation occurred but it was not as extensive as for the weekend stop since the temperature drop was not as large.

There was a 28% increase in lactic acid over the period. Nobel¹⁴ reports that the rate of deterioration increases with time, but when the juice was treated with a biocide, an initial period of 20 hours occurred during which little change in the apparent purity of the juice was measured. An untreated juice lost 2 units of purity in the same 20 hours. At Mount

Edgcombe biocide application into the clarifier over a 30 hour stop controlled microbial degradation. The lactic acid increase was only 15% compared to the normal 38%. The merits of biocide dosing¹⁵ into clarifiers, over weekend shut-downs on a regular basis, must be decided on a cost effective basis.

TABLE 6

Mean results for clarifier muds over an unplanned stop of 8½ hours.

Sample \ Test	T°C	Lactic acid /ppm on °brix
Shutdown	93°	940
Start up	85°	1 215

Laboratory experiments -

Under controlled conditions in the laboratory, juice and mud were allowed to deteriorate at elevated temperatures for twenty four hours and the extent of the deterioration was then measured.

Hyperthermophilic activity at 87°C was less than that at 80°C. This shows that although thermophiles can still grow and cause sucrose degradation at 87°C, growth was not as extensive due to the temperature being above the normal upper temperature limits. In addition Brock¹ postulates that the enzymes of thermophiles are not as efficient as those of mesophiles because of their increased heat stability.

During the incubation period there is an initial rapid growth phase which results in utilisation of nutrients and the build up of metabolic by-products. In a closed system, there is no outlet for these by-products, which in sufficient quantities cause growth inhibition. The drop in pH from 7,0 to 6,1 may inhibit the growth of hyperthermophiles having a pH optimum near 7,0.

Laboratory trials have confirmed that the major area of microbial activity in clarifiers is in the muds:

Incubation of muds, either in mixed juice or alone, resulted in deterioration occurring. Purity drops and increases in the lactic acid levels were monitored (see Table 7.)

Similar trends were observed for both mixed juice and for filtrate return incubations. The mixed juice deterioration in-

TABLE 5

Mean results for clarifier muds over the weekend shutdown of 16 hours.

Sample \ Test	T°C	pH	Reducing Sugars %	Sucrose %	Purity	Lactic acid/ppm on °brix
Shutdown	92°	6,9	0,572	10,84	84,5	810
Startup	83°	5,9	0,827	10,30	82,2	1 120

TABLE 7

Laboratory simulation of deterioration.

Sample \ Test	Incubation Temperature	Reducing Sugars %	Sucrose %	Purity	Lactic acid/ppm on °brix
Filtrate return into sterile mixed juice	80°C	0,42	8,91	89,10	360
		0,47	8,80	86,28	485
Mud into sterile mixed juice	87°C	0,60	4,47	78,20	3 860
		+0,60	4,37	75,90	4 305
Mixed juice	80°C	0,50	10,25	84,29	320
		0,52	10,18	78,13	430
Mud	80°C	0,35	11,04	85,32	605
		0,34	10,58	82,74	870

dicates the presence of thermophilic micro-organisms in the juice. Under the section entitled 'Normal clarifier operating conditions', it was established that mixed juice has a low thermophilic spore count (see Fig. 7) and it is these micro-organisms which are responsible for the deterioration. The microbial activity results in the increase in reducing sugar levels, and also contributes towards the sucrose loss.

Conclusions

Hyperthermophilic micro-organisms capable of sucrose destruction are present in clarifier juices and muds. A consequence of microbial activity is the formation of lactic acid. Increased residence time results in higher bacterial counts and hence increased lactic acid production. From such measurements an estimate of sucrose loss can be obtained.

In the conditions prevailing in the Mount Edgecombe clarifier station, sucrose loss occurred in clear juice, mud and filtrate return. In total this approximate sucrose loss was of the order of 0,05% on sucrose in mixed juice.

Hyperthermophilic microbial activity in the clarifier station is significant and cannot be ignored.

REFERENCES

1. Brock T. D. (1967) Life at high temperatures. *Science* **158**: 1012 - 1019.
2. Brock T. D. (1969). Microbial growth under extreme conditions. *Symp. Soc. Gen. Micro.* **19**: 14 - 41.
3. Abdou M. A. (1970). Über thermophile mikro-organismen in der Zuckerfabrikation. *Zucker* **23** (9): 259 - 264.
4. Gaughiran Eugene R. (1947). The thermophilic micro-organisms. *Bact. Rev.* **11**: 189 - 225.
5. McMaster L. D. and Ravnö A. B. (1975). Sucrose loss in diffusion with reference to thermophilic bacteria and lactic acid. *SASTA Proc.*: **49**: 49 - 52.
6. McMaster L. D. and Ravnö A. B. (1977). The occurrence of lactic acid and associated micro-organisms in cane sugar processing. *ISSCT Proc* **16** (in press).
7. Oldfield J. F. T., Dutton J. V. and Shore M. (1974). Effects of thermophilic activity in diffusion on sugar beet processing I and II *ISJ* **76**: 260 - 263 and 301 - 305.
8. Carruthers A. and Oldfield J. F. T. (1955). The activity of thermophilic bacteria in sugar beet diffusion systems. *British Sugar Corp. 8th Tech. Conf.*
9. Oldfield J. F. T. and Shore M. (1970). The measurement of lactic acid in beet sugar processing. I - A routine high precision method for the determination of lactic acid. *ISJ* **72**: 3 - 4.
10. Farrell J. and Rose A. (1967) Temperature effects on micro-organisms. *Ann. Rev. of Micro.* **21**: 101 - 120.
11. Hollaus F. (1978). The microbiology of beet sugar manufacture. *La Sucrierie Belge* **97**: 3 - 11.
12. Bevan D. and Bond J. (1971). Micro-organisms in field and mill - A preliminary survey. *QSSCT Proc* **38**: 137 - 143.
13. Henderson C. S. (1963). Some more on the weekend storage of subsiders. *QSSCT Proc.* **30**: 147 - 156.
14. Noble A. G. (1963). Factors affecting the deterioration of clarified juice. *QSSCT Proc.* **30**: 141 - 146.
15. Crowther J. (1967). The reduction of sucrose losses in clarifiers and milling tandems. *SASTA Proc.* **41**: 101 - 106.
16. Fields Marion L. (1970). The flat sour bacteria. *Adv. in Food Research* **18**: 163 - 217.