

PRELIMINARY APPRAISAL OF A CONTINUOUS CENTRIFUGAL OPERATING ON 'A' MASSECUITE AT ILLOVO FACTORY

By J. P. M. DE ROBILLARD : *Illovo Sugar Estates Ltd.*

and

G. JOURNET : *Fives Cail Babcock*

Abstract

A FC 1000 GCV SE 25° centrifugal, operating on 'A' massecuite, was tested at Illovo during the latter part of the 1979/80 crushing season.

The results obtained so far confirmed that, under controlled conditions, the machine produced a sugar which showed no significant difference (at 95% confidence level) in purity and grain size analysis in comparison with the conventional batch centrifugals. The average throughput for a locally acceptable VHP sugar was ± 12 metric tons of massecuite per hour.

History

Since 1968, Fives Cail Babcock has manufactured and tested continuous centrifugals for the sugar industry.

Initially these machines, equipped with 34° and 30° baskets, were designed to handle low purity massecuite and refinery magma respectively. However, in 1973, a machine equipped with a 30° basket was tested on 'B' massecuite, and the results were encouraging. They confirmed that granulometric degradation, due to erosion of the crystal over the screens, was always negligible when compared to the destruction caused by the impact of the crystal on the monitor casing at high speed. Furthermore, the results obtained from these tests allowed the development of a mathematical correlation between massecuite granulometry, speed of impact and crystal destruction, and the forecast of optimum conditions to prevent destruction on impact.

This empirical assessment prompted full scale research on the existing machines to extend this application to other higher grade products. Soon a wide range of commercial continuous machines made their appearance on the market, viz :—

- the FC 1000 GC3 in 1975,
- the FC 1000 SE 25° in 1977 and eventually,
- the FC 1000 GCV SE 25° in 1979 for operating on 'A' massecuite from cane.

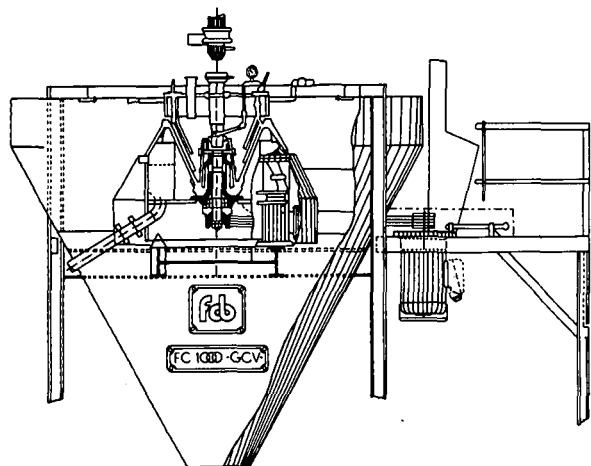

FIGURE 1 Basic features of the machine.

Basic Features of the Machine

The FC 1000 GCV SE 25° is a continuous centrifugal made up of a vertically mounted conical basket with a suspended molasses compartment, erected inside a very large diameter (5000 mm) stainless steel monitor casing. The basket has the following general characteristics :—

Angle	25°
Bottom diameter	430 mm
Top diameter	910 mm
Screening surface	1,2m ²

It is driven by a variable speed DC motor of 45 kw positioned outside the monitor casing and connected by vee belts. The two main bearings are grease lubricated. The massecuite is centre fed through an orifice guide, situated below the control valve, to the centrifugal and is distributed via an acceleration cone on to the deep screen clamping bowl before reaching the screens. The basket has two rows of thirty-six perforations each (of 5,5 mm \varnothing) halfway up, and rectangular slots at the periphery for molasses drainage. An interwoven stainless steel backing screen facilitates drainage of molasses over the whole basket.

A specially designed screen is fitted on top of the backing screen and is secured in the conventional way. However, the configuration of the perforations are different from the screen normally found in the industry, as the FC 1000 screen is divided into four unequal length segments from top to bottom (Figure 3). The bottom segment has round perforations of 0,16 mm \varnothing with a 5,5% open area the three other segments having rectangular slots of 0,13 mm x 1,72 mm with a 14% open area punched at different angles relative to one another. The main objectives of this design are to control drainage of molasses over the four segments so as to keep the moving crystals lubricated, and to increase the retention time of the crystals over the screen so as to maximise the washing effect and to induce drying of the crystal as well.

Wash water and steam are added radially, through an elaborate system of fine sprays, and coaxially at several points down the massecuite pipe from the feed valve to the accelerating bowl. The controls are centrally mounted on a console with rotameters for water flow measurements and pressure regulators for steam addition. A horizontal plate is rigidly suspended halfway up inside the basket from the casing cover in order to reduce or eliminate any steam or water spray, applied below the plate, from being entrained into the sugar compartment.

An extraction fan, positioned centrally above the top cover, is provided to remove any excess steam or water spray from the sugar compartment.

Experimental Design

The FC 1000 centrifugal is erected adjacent to a batch station, and is fully self-contained and receives identical massecuite, water and steam to the batch. The massecuite hopper is centrally situated above the machine (with a 3000 mm head) and massecuite flows through a vertical

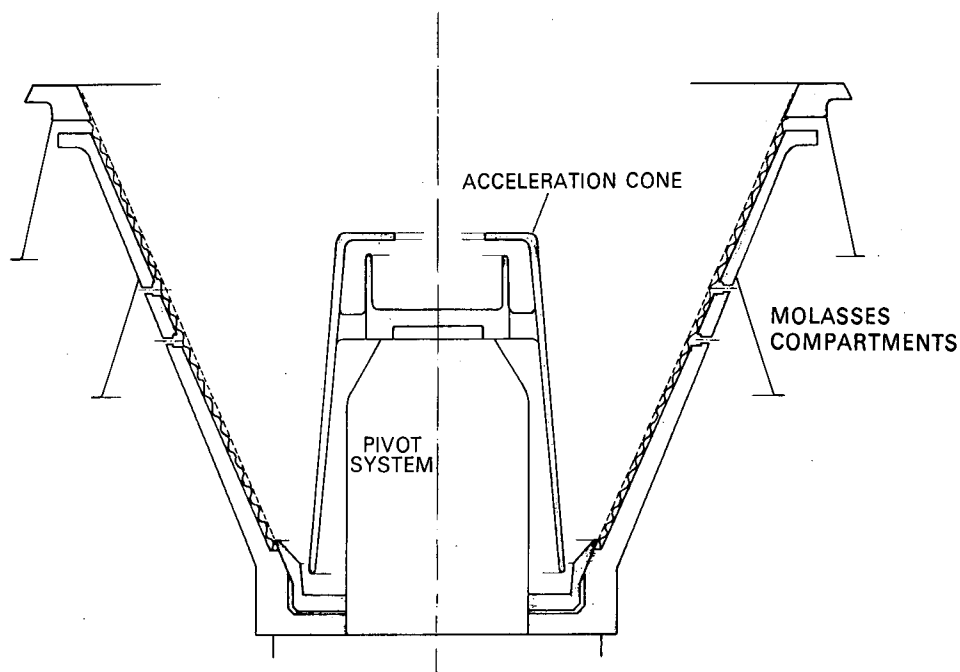

FIGURE 2 The FC 1000 GCVSE 25° basket arrangement.



FIGURE 3 Screen design.

200 mm Ø pipe via a pneumatic control butterfly valve. The level of massecuite inside the tank is kept constant by an overflow pipe.

The batch station comprises four standard BMA centrifugals (1219 x 762 mm — 1200 rpm). Each machine is rated

at approximately 7,0 tons of massecuite per hour, for approximately seventeen cycles per hour. Steam at 3,0 bar pressure and hot condensate water at $\pm 65^{\circ}\text{C}$ are injected into the basket on a control cycle. Since Illovo has no sugar drier as such, it is necessary that maximum drying is done in the batch centrifugal.

The tests were based on comparison of the sugars and molasses produced by the FC 1000 with those from the batch centrifugals processing the same massecuite. Sugar was sampled by running a scoop across the discharge belt of the FC 1000 and the grasshopper under the batch centrifugals at one minute intervals for fifteen minutes.

Molasses from both machines were sampled continuously by means of drip cocks during each run, also over the same period. Massecuite was sampled at the FC 1000 hopper and its capacity calculated by measuring the drop in level inside the feed tank over a given time. Sub-sampling and analysis were carried out in the factory laboratory using the official methods¹ and equipment.

Results and Discussions

In order to appraise statistically the performance and progress made by the continuous centrifugal FC 1000, it is necessary to divide the trial into two periods. The results for both the continuous and batch machines were systematically grouped in their own category and periods, irrespective of the operating variables, and were statistically analysed³.

(a) Period One :

This corresponds to the post commissioning time, i.e. beginning of September to mid October, during which time the centrifugal was subjected to a systematic programme of test work by Fives Cail Babcock personnel. This was followed by one week of comparison tests between the continuous and batch centrifugals under the control of the SMRI².

(b) *Period Two :*

This was in November and December, when the machine was under the control of the factory personnel.

1. *Masseccuite Throughput and Power Consumption*

Early in the trials the capacity of the continuous centrifugal, measured in metric tons of masseccuite per hour, was calibrated against motor amperage at three basket speeds. Provision was made for the physical properties of the masseccuite to remain unchanged during the tests.

The results listed in Table 1 below show a variation in capacity of 7 to 27 tons of masseccuite per hour for a range of amperage of 26,5 to 93,5. As can be expected, amperage is higher for the same throughput at higher speeds. This calibration was frequently checked during subsequent runs and found to be accurate.

TABLE 1
Capacity Rating vs Amps

Masseccuite in tons/h	Amps at 1 000 rpm	Amps at 1 200 rpm	Amps at 1 400 rpm
7	26,5	32,0	41,0
10	33,0	40,5	51,5
12	37,5	46,0	58,5
15	44,0	55,0	69,0
17	48,5	60,5	76,0
20	55,0	69,0	86,5
24	59,5	74,5	93,5
25	66,0	83,0	—
27	70,5	89,0	—

2. *Effect of Speed on Sugar and Molasses Analysis*

Moisture content of sugar decreased with increased speed of the basket and there was a corresponding increase in pol. However, there was no consistent effect of speed on molasses purity as shown in Table 2.

During the tests it was noted that, in the range 1200 to 1300 rpm, a maximum throughput of ± 13 tons of masseccuite per hour could be obtained with sugar meeting the VHP specifications. But, at the same throughput, with speed exceeding 1300 rpm grain size distribution would not meet specifications (Table 3) and the percentage of sugar lumps accumulated inside the monitor casing would increase; while at speed lower than 1200 rpm, pol was too low (Table 2).

Another factor which is not shown in the tables, but is nevertheless important, was the occurrence of large lumps of sugar. These lumps were formed when sugar dust (false grains, bagacillo, etc.) and entrained particles of vapour/water were in contact and accumulated in certain parts of the monitor casing and then broke loose. This problem was particularly evident at speeds exceeding 1200 rpm. The lumps escaped sampling because they were larger than the sampling scoop. In separate tests the proportion of lumps to sugar

on weight was found to be between 0,2 to 1,0% with a purity of $\pm 94^\circ$.

3. *Masseccuite Analysis*

The type of masseccuite processed during the tests must be considered as it has an important bearing on the performance of both batch and continuous centrifugals.

The viscosity of the masseccuite was noticed to have little effect on the FC 1000 amperage at same throughput, but affected the sugar quality. The viscosity of the masseccuite during the tests ranged from 24880 to 52000 centipoises @ 57°C. Measurements were made with a Brookfield viscometer type RvF 1200. Masseccuite brix, purity and nutsch purity for the two periods under consideration are listed below in Table 4. The table shows that there is statistically no significant difference in masseccuite brix or nutsch purity between the two periods, while there was however, a significant drop in masseccuite purity between the first and second series of tests.

4. *Sugar Analysis*

One of the objects of the tests was to establish the difference in quality between the sugars produced by the FC 1000 and the batch machines from the same masseccuite. However, it must be emphasised that the batch centrifugals were operating under normal factory conditions, whereas the FC 1000 was under test, thus operating conditions varied. It was therefore necessary to establish if the results of each type of machine were consistent and if the differences between the two types were statistically significant, as illustrated in Table 5.

Table 5 shows that :—

- In spite of a drop in masseccuite purity between period 1 and 2, (Table 4) there was a significant improvement in the pol of sugar produced by the FC 1000. Period 1 shows a significant difference in pol of sugar between the batch and the continuous, whilst in period 2 there is no significant difference which is an indication that the performance of the FC 1000 had improved to the level of the batch machine. This improvement was attributed to a change in moisture level of the sugar, since sugar purity was the same for both type centrifugals during all tests.
- Sugar from the batch machines had significantly lower colour (0,049 @ 560 nm) for the first series of tests, but there was no significant difference between the sugars produced during the second set of tests. This improvement in performance of the FC 1000 machine was mainly due to change in wash water, and steam application.
- Grain size analysis of the sugars from both types of machines showed no significant differences. This was confirmed by microscopic examinations of the sugar from the FC 1000 centrifugal.

TABLE 2
Basket Speed v/s Sugar and Molasses Analyses

Fc 1000			Sugar			Molasses	Masseccuite		Nutsch
Amps	Cap. Mt./h	Speed r.p.m.	% H ₂ O	Pol	Purity	Purity	Brix	Purity	Purity
37,5	13	1 000	0,669	98,80	99,45	67,57	94,65	87,16	66,24
42,0	13	1 100	0,528	98,95	99,48	68,73			
46,0	13	1 200	0,518	99,10	99,62	65,86			
52,0	13	1 300	0,429	99,30	99,73	68,26	94,58	87,26	66,00
58,5	13	1 400	0,435	99,30	99,73	69,05			

5. Molasses Purity

The results of purity drop between massecuite and molasses which is another important criterion of centrifugal performance. Both machines were of course fed with the same massecuite. The results are summarised and listed in Table 6.

TABLE 3
Grain size analysis Fc 1000

Sieve size	Masseccuite affinated	Sugar at 1 000 rpm	Sugar at 1 200 rpm	Sugar at 1 400 rpm
mm	% total mass of sugar retained	% total mass retained	% total mass retained	% total mass retained
1,70	0,29	0,19	0,20	0,09
1,18	2,64	2,26	2,86	1,69
1,00	6,15	9,42	6,52	6,75
0,60	63,09	61,63	60,57	57,64
0,355	24,02	23,36	25,30	27,98
0,242	2,93	2,26	3,46	4,27
0,125	0,78	0,68	0,89	1,28
0	0,10	0,20	0,40	0,30
MA mm =	0,74	0,75	0,73	0,71
CV% =	31,2	30,3	32,3	32,5
SGS mm =	0,63	0,65	0,62	0,60
% > 1,18 =	2,9	2,5	3,1	1,8
% < 0,6 =	27,48	26,5	29,9	33,8

As can be expected with any continuous centrifugal operation, molasses dilution with the FC 1000 was found to be significantly greater. However, in the case of purity, only during period 1 was the difference significant in favour of the FC 1000, while during period 2 the difference was not significant probably because of the wide scatter in purities.

Conclusions

The FC 1000 continuous centrifugal, which was originally rated by the manufacturers at ± 20 tons of 'A' massecuite per hour was found to have a throughput of only ± 12 MT per hour when producing sugars meeting S.A. Sugar Terminal VHP specifications.

On cost effectiveness the relatively low throughput compared to the installed price and the huge size of the monitor casing have proved to be the main limitations of the machine.

Grain size analysis of the FC 1000 sugar was as good as for the batch machines and there was no evidence of higher crystal breakage. (The moisture content of the sugar (0,25 to 0,50%) at speeds up to 1200 rpm was significantly higher than for the batch which was producing sugars of low moisture content (0,05 to 0,18%). At higher sugar moisture level i.e. + 0,5%) encrustation of the monitor casing with wet sugar was a physical limitation.

TABLE 4
Massecuite analysis period 1 vs period 2

Factors	Period 1		Period 2		Diff.	t Calculated	t 0,05	Significant
	Mean	Std. Dev.	Mean	Std. Dev.				
Masseccuite purity	85,76	0,7190	84,36	0,6506	1,40	5,196	2,00	+
Masseccuite brix	92,14	0,5197	92,12	0,7606	0,02	0,091	2,00	-
Nutsch purity	64,69	1,3798	64,01	2,0015	0,68	1,500	1,989	-

TABLE 5
Sugar Analysis

Factors	FC 1000		Batch		Difference (Batch -cont)	t calc	t 0,05	Significant
	Mean	Std. Dev.	Mean	Std. Dev.				
Pol Period 1	98,947	0,21214	99,178	0,23701	0,251	4,217	2,00	+
Pol Period 2	99,202	0,2646	99,243	0,4807	- 0,039	0,230	2,120	-
Purity Period 1	99,278	0,2168	99,330	0,2033	0,052	0,909	2,00	-
Purity Period 2	99,402	0,2456	99,380	0,4147	- 0,022	0,048	2,086	-
Colour Period 1*	0,259	0,0543	0,210	0,0344	0,049	2,907	2,056	+
Colour Period 2*	0,312	0,1253	0,273	0,1375	0,174	0,530	2,228	-
S.G.S. (period 1 and 2) mm ..	0,600	0,0362	0,605	0,0447	0,005	0,2457	2,145	-
M.A. (period 1 and 2) mm ..	0,725	0,0300	0,727	0,0479	0,002	0,1062	2,447	-
CV (period 1 and 2)%	32,50	1,9148	33,75	2,9861	1,25	0,7049	2,447	-
% Fines (period 1 and 2)	36	8,602	33	7,396	- 3	0,7780	2,145	-

* (560 nm)

TABLE 6
Molasses Analysis

Factors	FC 1000		Batch		Difference (Batch cont)	Calc t	t 0,05	Significant
	Mean	Std. Dev.	Mean	Std. Dev.				
Brix Period 1	75,57	1,0431	77,17	1,5697	1,60	4,203	2,042	+
Brix Period 2	74,84	1,2957	77,82	1,7426	2,98	4,548	2,086	+
Purity Period 1	66,43	1,0635	67,53	0,9386	1,10	3,912	2,00	+
Purity Period 2	66,19	1,0148	67,32	1,7256	1,13	1,865	2,086	-

Because of the higher moisture content, pol of sugar from the continuous machine was obviously lower than pol for the batch, although there was no significant difference in purity between the two sugars during both test periods.

The difference in colour between the sugars from the batch and FC 1000, which favoured the batch machines during the first period, was also eliminated in the second comparisons.

Production of an appreciable proportion of large lumps of sugar dust was an objectionable characteristic of the FC 1000 centrifugal. Operationally, the machine was very simple and easy to control, though it requires good supervision. Running costs and power consumed are much lower than the batch machines. Generally, it can be stated that the performance of the FC 1000 machine on 'A' massecuite has been favourable, although more development work is necessary to overcome the problems of lump formation and high sugar moisture content. The development of a smaller monitor casing is also warranted.

Acknowledgements

The authors would like to extend their thanks to the laboratory staff of Illovo, in particular Mr. J. M. Thomas, and the analytical department of the SMRI for their assistance and co-operation in the sampling and analytical work. The contributions of both Mr. J. P. Lamusse of SMRI and K. Taylor of Smithtech for their technical and statistical assistances are gratefully acknowledged. We would also like to thank the management of Illovo Mill and the board of C. G. Smith Sugar for permission to publish this paper.

REFERENCES

1. Anon (1977). Laboratory manual for South African Sugar Factories. S.A. Sugar Technologist Association — Durban.
2. J. P. Lamusse, N. Dunsmore, J. Hoines (1979) SMRI — Technical report No. 1202.
3. Volk, W. (1969). "Applied statistics for Engineers". 2nd edition, McGraw — Hill — New York.