

AN EVALUATION OF A NUCLEAR DENSITY GAUGE FOR MEASURING INFIELD COMPACTION IN SOILS OF THE SOUTH AFRICAN SUGAR INDUSTRY

By J. M. SWINFORD and J. H. MEYER

S.A. Sugar Association Experiment Station, Mount Edgecombe, 4300

Abstract

A gamma-ray attenuation method for determining bulk density to a depth of 300 mm in the field is described. Tests which were conducted on plots in a compaction trial showed that the method was as accurate as the standard core sampling procedure and up to five times faster. The results also indicated that the compacted layer was situated at a depth between 150 and 200 mm which was consistent with measurements obtained with the hand penetrometer. Regression analysis indicated that plant performance, when measured in terms of sucrose yield, was negatively correlated with bulk density values obtained at a depth of 200 mm by both the gamma-ray and undisturbed core methods. The simplicity of operation and ruggedness of the equipment makes it useful for survey and advisory work.

Introduction

Because infield operations have been mechanized considerably during the past two decades, compaction of the soil and its effect on crop growth has received increasing attention by many agricultural researchers. Some examples of research conducted in South Africa include the influence of soil strength on plant growth (Bennie and Laker¹; Mallet⁴) and the influence of texture (van der Watt²; Moolman⁶), moisture holding capacity and organic matter content (Maud⁵) and crust formation (Weber and van Rooyen¹¹; Hutson²) on soil compactibility. In the sugar industry, field investigations have indicated that sugarcane growing in soils of the Longlands and Westleigh forms is more prone to severe damage due to soil compaction (Swinford and Boevey⁸) than cane growing in clay loam soils of the Hutton form (Johnston and Wood³).

In the past, methods based on some form of penetrometer measurements have been used to assess the degree of compaction in the field. Penetrometers have the advantage of simulating the action of plant roots in a soil, by measuring soil strength/shearing resistance, but a disadvantage is that reliable results can only be obtained when the moisture content of the soil is close to field capacity. Measurements of the bulk density of the soil, by means of undisturbed cores, can be used to assess soil compaction. This method is more reliable but unfortunately very time consuming, particularly when large areas are involved and separate samples have to be taken to depth.

The gamma-ray radiation bulk density meter which was pioneered by Vomocil¹⁰ and developed further by Soane⁷, offers a direct means of determining bulk density in the field. It is as accurate as the core sampling method but up to five times faster. This technique is widely employed by civil engineers in foundation and road construction work, but its use by agriculturalists has been limited in this country. These considerations led to a closer investigation of the merits of using a nuclear bulk density meter for assessing compaction problems in the field.

Experimental procedure

Equipment

Several commercial devices are available on the market but the Troxler nuclear density and moisture gauge (model 3411 B, see Figure 1) was evaluated because it is equipped with both

neutron and gamma-ray sources which enable bulk density and moisture to be determined simultaneously. This instrument has a single probe which provides for both gamma-ray scattering and gamma-ray transmission depending on the required depth of measurement. Surface measurements (0 to 100 mm integrated) are made with the backscatter technique (Figure 2) and the measurements between 50 and 300 mm are made using the gamma-ray transmission mode (Figure 3).



FIGURE 1 Troxler nuclear density and moisture gauge.

The single probe houses two sealed sources, an 8 millicurie glass-bead source of caesium-137 (half life 30 years) to provide gamma radiation for the density measurement, and a 40 millicurie americium-241: beryllium source (half life 458 years) yielding 70 000 neutrons per second for moisture determination. Two Geiger Müller detectors for density measurement and a helium-3 detector for moisture measurement are housed in the body of the instrument (Figure 2).

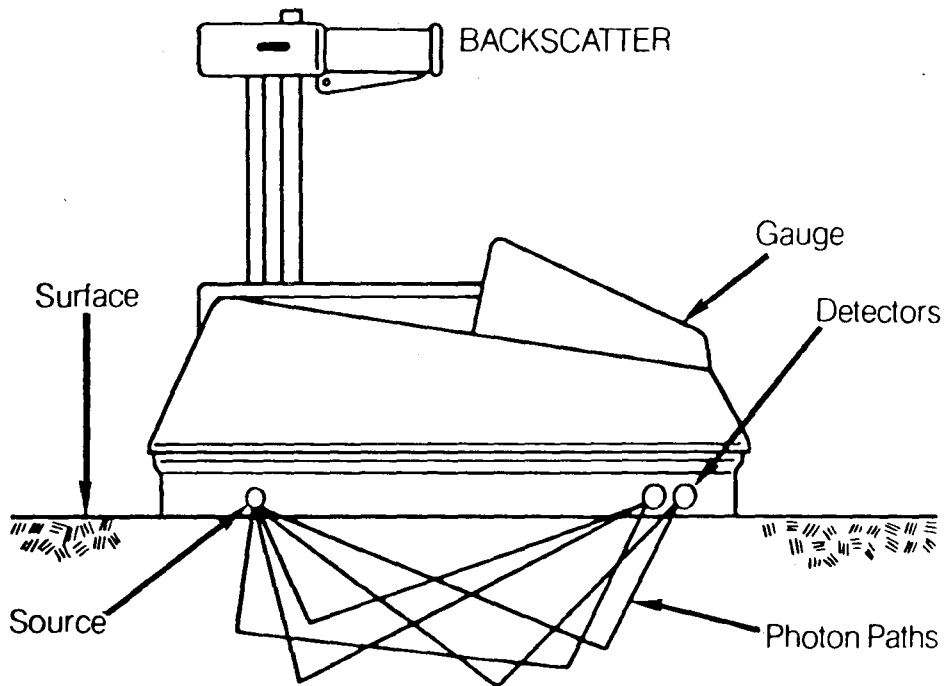

FIGURE 2 Troxler density gauge shown measuring in the backscatter mode.

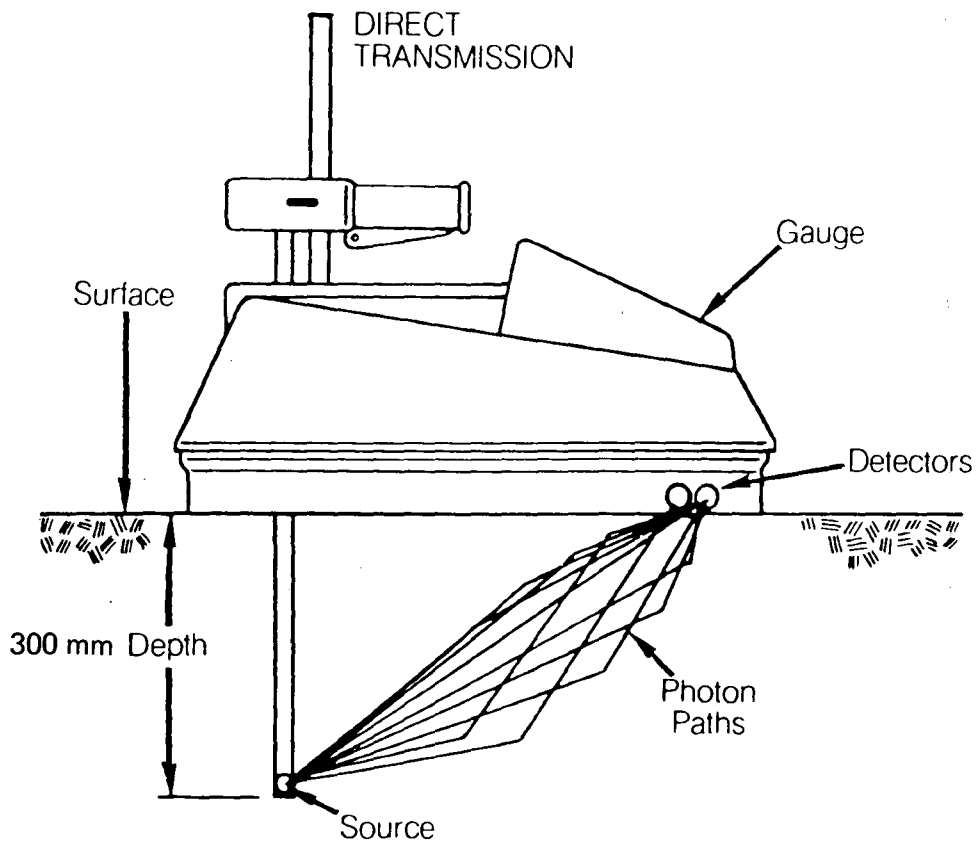

FIGURE 3 Troxler density gauge shown measuring in the direct transmission mode.

In practice, the instrument is placed on a calibration block of standard density and the count rate is measured over a pre-set time and checked against specifications which are provided. The site must be about 250 × 250 mm of soil which has been smoothed by removing all dried and loose material. Fine sand is sprinkled over the surface to fill any small voids or cavities remaining after removing stones. The instrument is then placed firmly on the surface and with the probe in the backscatter

position, the surface moisture and density counts are measured after one minute. Where readings are required to depth, the gauge must be removed from the site and a hole prepared by driving a spike through an alignment jig to the required depth. The gauge is then replaced on the site, the probe lowered and moisture and density measurements are made in the transmission mode. Once the instrument is set, the whole operation takes only a few minutes.

Field procedure

Site selection

The initial testing of the Troxler was conducted on a compaction trial on a Longlands soil form at the La Mercy farm which is situated about 30 km north of Durban. This trial has yielded two ratoon crops and in both, the moderate and severe compaction treatments over the cane row resulted in a marked reduction in yield. The treatments tested were:

- C1 — control (no compaction)
- C2 — moderate compaction on the interrow (3,7 ton load)
- C3 — moderate compaction on the interrow and row (3,7 ton load)
- C4 — severe compaction on the interrow (5,7 ton load)
- C5 — severe compaction on the interrow and row (5,7 ton load)

Measurements with the Troxler gauge

The performance of the Troxler gauge was assessed by comparing it with the hand penetrometer and undisturbed core sampler, and relating yield performance to Troxler bulk density measurements.

In the first investigation, the control (C1), moderate (C3) and severe (C5) compaction treatments were applied on four replicate plots:

- three undisturbed core samples were taken down the profile (0 to 300 mm) in each plot. The height of the core tin was 80 mm and the depths sampled were 20 to 100 mm, 120 to 200 mm and 220 to 300 mm. One set of profile samples was taken in each of 12 plots. Moisture content of the cores was also determined on an oven dry basis

- penetrometer measurements were taken to a depth of 400 mm using three replicates per plot
- wet and dry bulk density measurements and moisture contents were determined with the Troxler gauge at 50 mm intervals to a depth of 300 mm with one set of readings per plot.

In the second investigation the Troxler gauge was used to measure wet and dry bulk density values at the surface and at a depth 200 mm between the third and fourth row at both ends of each plot.

Results

Comparison of Troxler with core sampling and hand penetrometer methods

The average results from using these methods are given in Table 1 and the effects of measuring compaction to depth are shown in Figures 4 and 5. In general, all three methods reflected the effects of the compaction treatments to a maximum depth of 300 mm. With few exceptions, bulk density values using both methods increased by an average of 7% due to compaction.

In the uncompacted plots, wet bulk density values tended to be below 1,80, increasing to between 1,80 and 1,90 for the moderately compacted plots and to above 1,90 in the severely compacted plots. Troxler measurements also showed the expected compacted layer to be situated at a depth between 150 and 250 mm in all the severely compacted plots and in some of the moderately compacted plots (Figure 5).

TABLE 1
Comparison of three methods for measuring the effects of compaction to depth

Treatments	Depth (mm)	Hand penetrometer values (N/cm ²)	Wet density (kg/m ³)			Dry density (kg/m ³)			Yield	
			Core sampler	Troxler	Diff. %	Core sampler	Troxler	Diff. %	tc/ha	ts/ha
Control (C1)	100	183	1 786	1 791	+ 0,3	1 654	1 658	+ 0,3	80	8,0
	200	179	1 775	1 798	+ 1,3	1 596	1 617	+ 1,3		
	300	148	1 717	1 801	+ 4,9	1 580	1 657	+ 4,9		
Moderate compaction (C3)	100	256	1 897	1 842	- 2,8	1 728	1 676	- 2,8	58	5,2
	200	238	1 874	1 867	- 0,4	1 712	1 706	- 0,4		
	300	257	1 868	1 866	0	1 714	1 704	0		
Severe compaction (C5)	100	273	1 919	1 865	- 2,8	1 767	1 714	- 2,8	61	5,7
	200	277	1 904	1 918	+ 0,7	1 768	1 781	+ 0,7		
	300	320	1 862	1 907	+ 2,4	1 705	1 744	+ 2,4		
Mean of 12 plots	100	237	1 867	1 833	- 1,8	1 716	1 683	- 1,9	66	6,3
	200	231	1 884	1 861	- 1,2	1 692	1 701	+ 0,5		
	300	242	1 816	1 858	+ 2,3	1 666	1 702	+ 2,2		
Correlation with yield: r values (tc) (ts)	100	0,42	0,56	0,74**	—	0,59*	0,53	—	—	—
		0,64*	0,75**	0,78**	—	0,70*	0,40	—	—	—
r values (tc) (ts)	200	0,48	0,69*	0,73**	—	0,72**	0,69*	—	—	—
		0,58*	0,68*	0,79**	—	0,70*	0,71**	—	—	—
r values (tc) (ts)	300	0,42	0,75**	0,58*	—	0,64*	0,32	—	—	—
		0,42	0,49	0,61*	—	0,59*	0,25	—	—	—
Correlation: Troxler vs cores (wet density)	100	—	0,63*	—	—	0,19	—	—	—	—
	200	—	0,74**	—	—	0,83***	—	—	—	—
	300	—	0,61*	—	—	0,61*	—	—	—	—
All plots	—	—	0,58***	—	—	0,60***	—	—	—	—

* 5% level of significance
 ** 1% level of significance
 *** 0,1% level of significance

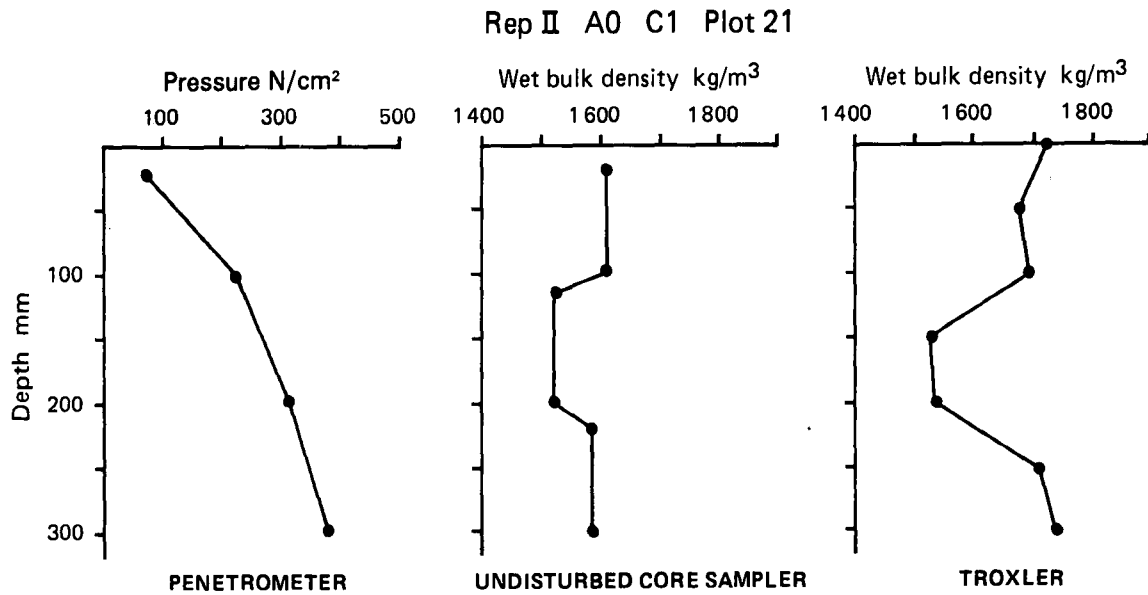

FIGURE 4 Comparison of three methods of measuring natural compactive effects to depth (Control - uncompacted treatment).

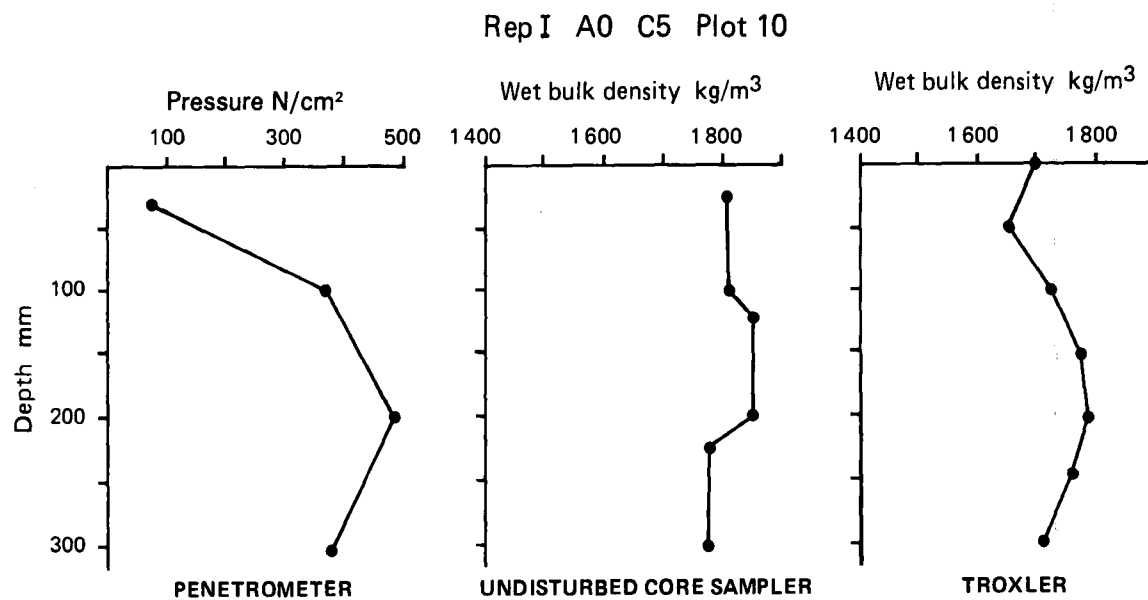

FIGURE 5 Comparison of three methods of measuring the effects of severe compaction to depth.

The relationship between the Troxler results and the penetrometer measurements was poor but there was satisfactory agreement with the undisturbed core method. Regression analyses confirmed that the two methods were reasonably well correlated with bulk density values between 1 500 and 2 000 kg/m³. An examination of the results for individual plots showed that the differences between the two methods were less than

4% of the Troxler value in 75% of the plots that were tested.

Additional tests conducted at four different sites on five separate occasions showed that bulk density values obtained with the Troxler were very reproducible (Table 2). Standard deviation values were within the 2% tolerance limits allowed by the manufacturer.

TABLE 2
Wet bulk density values recorded during reproducibility tests on a Longlands soil form

Site	Bulk density (kg/m ³) and days											
	1		2		3		4		5		Mean	
	*DD	**WD	DD	WD	DD	WD	DD	WD	DD	WD	DD	WD
1	1 625	1 754	1 626	1 750	1 589	1 716	1 621	1 742	1 606	1 731	1 613	1 739
2	1 657	1 823	1 650	1 808	1 642	1 779	1 649	1 777	1 634	1 773	1 646	1 792
3	1 666	1 797	1 692	1 821	1 676	1 794	1 669	1 778	1 688	1 801	1 678	1 799
4	1 721	1 847	1 708	1 844	1 718	1 847	1 723	1 845	1 713	1 838	1 717	1 844

* DD = Dry density
** WD = Wet density

Assessment of Troxler in terms of yield performance

The harvest data in the compaction trial clearly showed the damaging effect which soil compaction had on cane yield. Regression analysis indicated that sucrose yield from the 12 plots was negatively correlated with wet density values determined by the Troxler or undisturbed core sample methods. Overall, yields correlated slightly better with the Troxler than with the undisturbed core method. The coefficients of correlation in Table 1 indicate that yield correlated best with Troxler values measured at a depth of 200 mm. This confirmed that the maximum compaction effect was likely to be at or near this depth. The slope of the regression lines at the 200 mm sampling depth (Figure 6) shows the greater sensitivity of the Troxler method compared with the undisturbed core sampling method in reflecting changes in yield caused by compaction.

The yield/bulk density relationship referred to previously was verified by repeating the exercise on all the plots of the trial. Half the plots were ripped in the interrow and the other half were not ripped. The mean yield data obtained for the 1982 and 1983 harvests and the Troxler values obtained for the various compaction treatments are summarized in Table 3. As before, yields were inversely related to bulk density values and the two regression lines were highly significant for the unripped plots only (Figures 7 and 8).

Discussion

There was no marked correlation between yield and bulk density values in the ripped plots but this was not surprising because the soil was still noticeably disturbed when the Troxler tests were being carried out. Correlations may have been better if more bulk density readings had been taken per plot. The response to ripping in the compacted plots was associated with a marked reduction in bulk density (Table 3).

The results obtained in this investigation suggest that the mean bulk density values obtained by the Troxler are unlikely to differ significantly from those obtained by core sampling. The undisturbed core sampling method cannot be used as an absolute standard since compaction can occur within the core and the size and shape of the core is different from the volume of soil which influences the gamma-ray transmission reading.

No worthwhile comparisons could be made between the Troxler and the hand penetrometer methods because the severe compaction treatments did not always produce the highest resistance values. It was thought that shear failure had caused a partial loosening of the soil mass as a result of severe disruption. Many other factors are known to influence resistance of a soil to penetration. These include the effects of compaction, moisture content, texture, type of clay mineral and shape of the probe. Moisture content may vary down a profile and has a major influence on readings. A marked resistance to penetration occurs with decreasing moisture content, which indicates that the strength of the soil becomes greater as it dries and the constituent particles are brought together. Unfortunately, there is no simple relationship between penetration readings and moisture content of the soil. This method cannot therefore be used as a reference.

The Troxler method of determining bulk density by gamma-ray transmission is not greatly affected by factors that can affect the accuracy of the penetrometer method. Bulk density values can be determined over a wide range of soil moisture contents and dry bulk density values can be determined by the Troxler gauge after correcting for moisture content. The main advantage of the Troxler is that it is very much quicker than the core sampling methods. It was generally possible to complete measurements at four positions with the gauge in about one-fifth of

the time required for a similar number of cores. A disadvantage of the instrument is that readings can only be taken to a depth of 300 mm. Depths greater than 300 mm require the use of pits or trenches which are stepped at intervals of 300 mm. Another possible criticism of the Troxler method is that it cannot detect thin compacted layers in the soil as the instrument takes an integrated reading between the gamma source in the probe tip and the detector at the soil surface. Some dual probe instruments can be used to determine the bulk density in 15 mm layers and these are more suitable for highly specific work.

Conclusions

Although further work is required on a wider range of soils, there is good reason to believe from these preliminary results that the Troxler gauge will be very useful in identifying soil compaction problems. If it is assumed that these results are representative of the Longlands form soil, then bulk density values of 1,80 (in the moist state) or 1,65 (in the dry state) may provisionally be taken as the critical values. Poorly developed root systems and poor yields are likely to result where cane is grown on soils of this form with bulk density values higher than the appropriate critical value.

Narrow compacted layers in a soil profile cannot be accurately detected with this instrument but increased bulk density to a depth of 300 mm can be identified in the field within minutes, compared with the two to three days required for undisturbed core samples. The simplicity of its operation and its ruggedness makes this meter ideally suited to large-scale surveys which can be conducted with a minimum of manpower.

TABLE 3
Summary of yields obtained for the 1982 and 1983 harvests in relation to Troxler bulk density values

Compaction treatments	Yield				Troxler density (kg/m ³)	
	1982		1983		Dry density 200 mm	Wet density 200 mm
	tc/ha†	ts/ha††	tc/ha	ts/ha		
C1	80	7,9	34	3,6	1 576	1 765
C2	69	6,1	25	2,5	1 697	1 867
Unripped C3	58	5,2	20	2,2	1 698	1 875
C4	63	5,8	22	2,3	1 697	1 891
C5	61	5,6	18	1,9	1 702	1 893
Wet density 200 mm: r values	0,83**	0,82**	0,84**	0,82**	—	—
Dry density 200 mm: r values	0,69**	0,77**	0,63*	0,59*	—	—
C1	76	7,3	33	3,5	1 493	1 686
C2	81	8,1	34	3,9	1 575	1 748
Ripped C3	69	6,5	31	3,4	1 674	1 865
C4	68	6,2	29	3,0	1 675	1 840
C5	64	6,1	23	2,5	1 680	1 868
Wet density 200 mm: r values	0,60*	0,61*	0,37	0,40	—	—
Dry density 200 mm: r values	0,64*	0,59*	0,32	0,34	—	—

† tc/ha = tons cane per hectare
 †† ts/ha = tons sucrose per hectare
 * 1% level of significance
 ** 0,1% level of significance

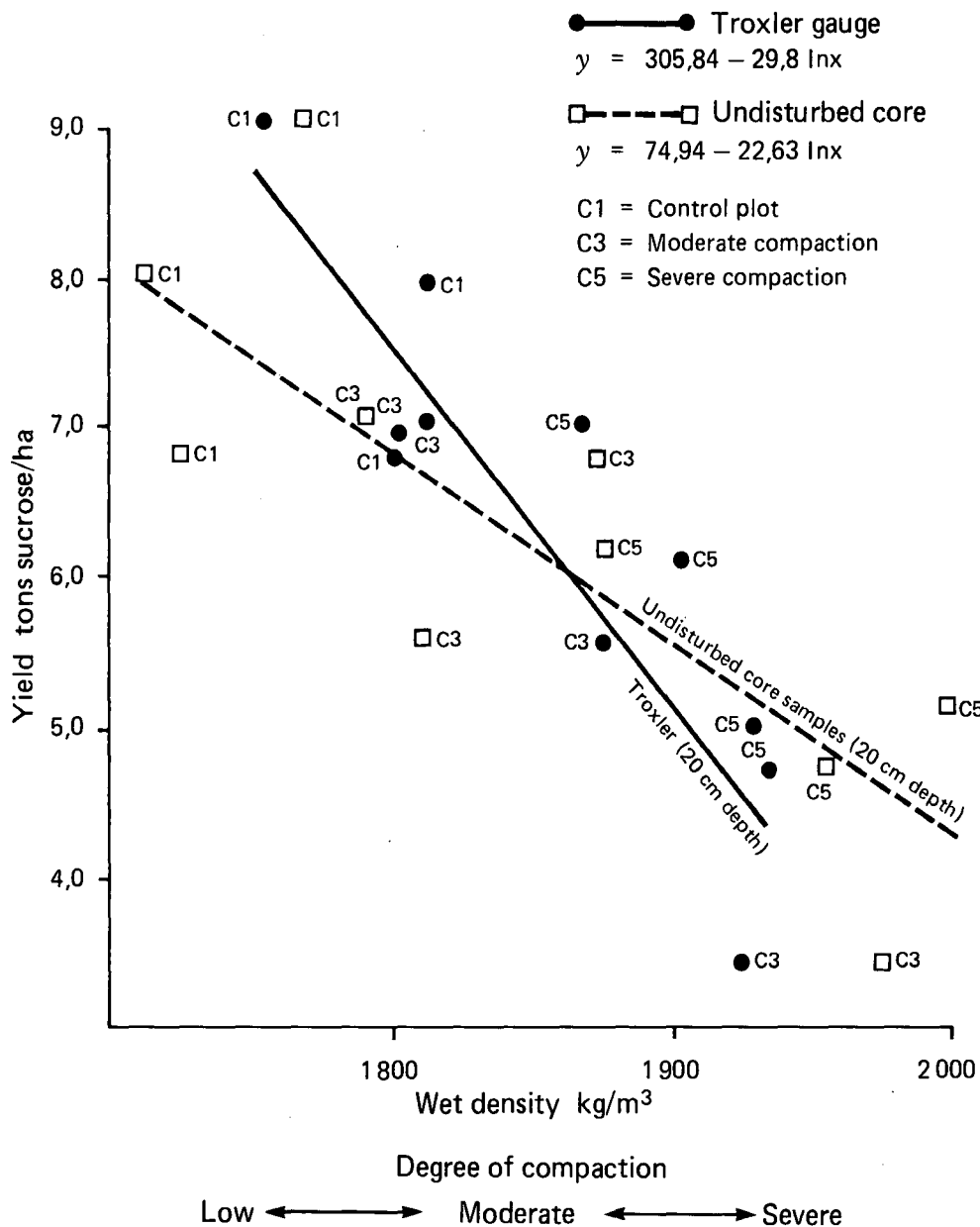

FIGURE 6 Yield in relation to soil wet density as determined by two methods.

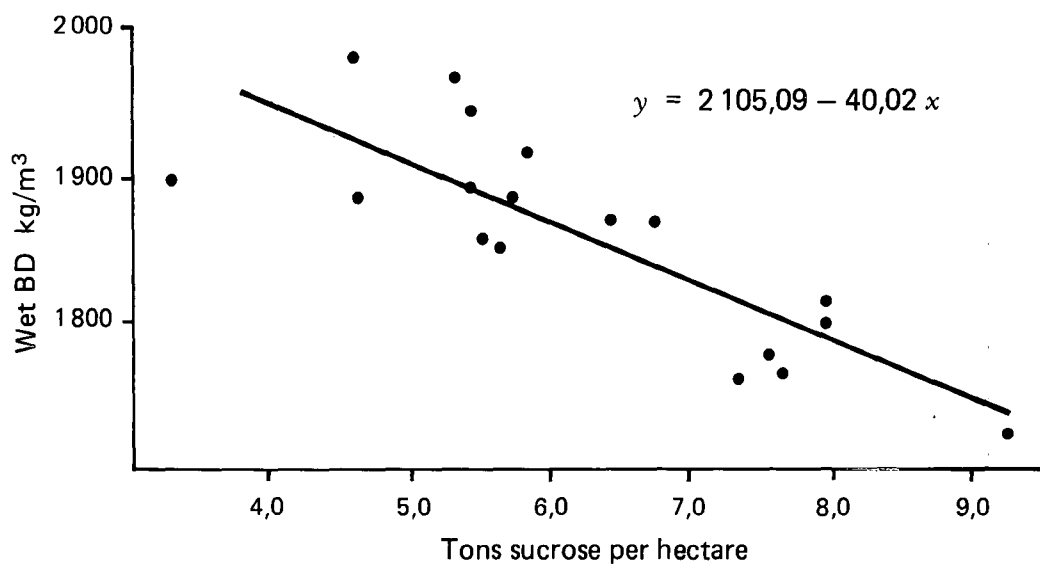

FIGURE 7 Yield in relation to Troxler wet density values at 200 mm depth (1982 crop).

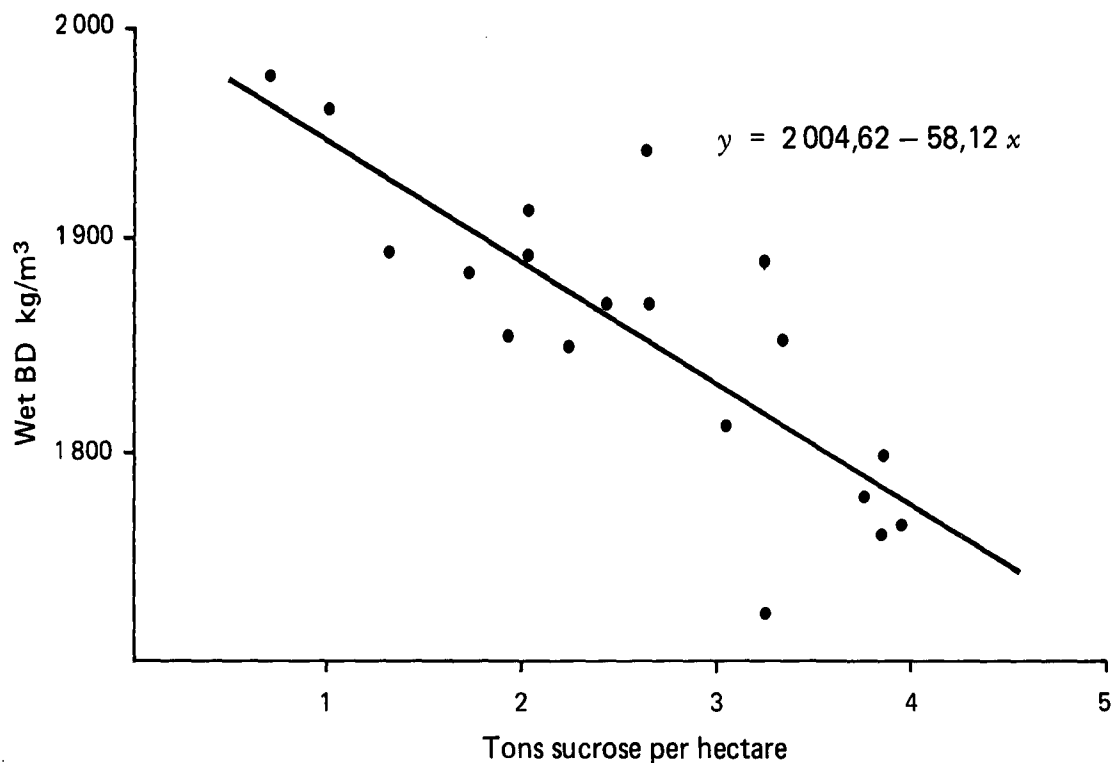

FIGURE 8 Yield in relation to Troxler wet density values at 200 mm depth (1983 crop).

Acknowledgements

The authors wish to thank Mr M. J. Copeland for his participation in the initial stages of the project; Messrs V. Dorasamy and A. Govender for their assistance with the field investigations; and Dr R. A. Wood for his helpful advice.

REFERENCES

- Bennie, ATP and Laker, MC (1975). The influence of soil strength on plant growth in red apedal soils. *Proc. Natn. Congr. Soil Sci. Soc. S. Afr. (Blydepoort)*, 6: 259-275.
- Hutson, JL (1971). Crust formation on some Natal Soils. *M.Sc. Agric. thesis, Univ. Natal.*
- Johnston, MA and Wood, RA (1971). Soil compaction at Pongola. *Proc. S. Afr. Sug. Technol. Ass.* 45: 261-269.
- Mallet, JB (1982). Tillage and its effects upon physical properties of some South African soils. *9th Conference of the International Soil Tillage Research Organisation, Socialistic Federal Republic of Yugoslavia, Osijek*, 126.
- Maud, RR (1960). The compaction of sugar-belt soils at various moisture levels. *Proc. S. Afr. Sug. Technol. Ass.* 3-4: 154-160.
- Moolman, JH (1981). Soil textural properties influencing compactibility. *Proc. 10th Natn. Cong. Soil Sci. Soc. S. Afr.* 164.
- Soane, BD (1971). Hand held gamma-ray transmission equipment for the measurement of bulk density of field soils. *J. Engng Res.* 16: 146-156.
- Swinford, JM and Boevey, TMC (1984). The effects of soil compaction due to infield transport on ratoon cane yields and soil physical characteristics. *Proc. S. Afr. Sug. Technol. Ass.* 58: 198-203.
- Van der Watt, HvH (1969). Influence of particle size distribution on soil compactibility. *Agrochemophysica* 1: 79-86.
- Vomocil, JA (1954). *In situ* measurements of soil bulk density. *Agric. Engng. St. Joseph, Mich.*, 35: 651-654.
- Weber, HW and Van Rooyen, PC (1971). Polysaccharides in molasses meal as an ameliorant for saline-sodic soils compared to other reclamation agents. *Geoderma* 6: 233-253.