

# THE USE OF HAND-OPERATED SPRAYERS FOR AGRICULTURAL CHEMICALS IN THE SOUTH AFRICAN SUGAR INDUSTRY

By T. M. C. BOEVEY and J. P. FOURIE

South African Sugar Association Experiment Station, Private Bag X02, Mount Edgecombe 4300

## Abstract

Knapsack sprayers are commonly used for the application of agricultural chemicals in the South African sugar industry. Ultra-low volume (ULV) spinning disc type applicators are also available. The cost of chemicals per unit area is high when compared with the cost of application. It is for this reason that the application techniques are often overlooked. Even if a sprayer is correctly calibrated, the way in which it is used by the operator, particularly for extended periods, may affect the application rate causing it to vary. This could result in an uneven distribution and contribute to poor results. The performance and output of six knapsack sprayers and two ULV applicators were tested under experimental conditions. These results were used as standard values when comparing other sprayers. The relative merits of the applicators and the way in which they were used are discussed. The modifications and developments that were necessary to achieve a higher degree of accuracy in the application of chemicals are also discussed.

## Introduction

Results from previous research into the effects of pressure and nozzle type on spray patterns have resulted in recommendations that herbicides be applied in 200 to 400 l water ha<sup>-1</sup> at pressures of 150 to 200 kPa with the equipment available (ie no tests were done on low volume sprayers)

(Turner, personal communication). Chemical manufacturers agree that a rate of approximately 200 l ha<sup>-1</sup> or more is required for the droplets to be distributed sufficiently over the target area to obtain the best effect.

Pre-emergence herbicides are applied before weeds appear and a lower application rate per unit of area than for post-emergence herbicides is acceptable. Ultra-low volume (ULV) sprayers are more suitable for the pre-emergent application of herbicides. The lack of droplet momentum prevents adequate penetration of a post-emergence herbicide into an existing weed population.

The rate of discharge of knapsack sprayers depends mainly on the selected nozzle size and the pumping rate, so these factors determine both the output volume and pressure. The application rate per unit of area will be affected by full or partial coverage, swath width, spray overlap, and walking speed. All the sprayers were bench-tested to determine their output in terms of volume and pressure for a range of pumping rates and at all settings the maximum pumping stroke was used. The results are therefore based on the maximum potential output for each sprayer.

## Method

Six knapsack sprayers were mounted onto a stand for bench-testing and the pumping lever was coupled to a pitman driven by a hydraulic motor. The motor speed was

Table 1

Features of six different knapsack sprayers

	Cooper Pegler 3 Mk 2	Hardi RY2	Hardi RY15	Spraying	PTP 20	Hudson 67367
<b>Tank:</b> Rated capacity (l)	20	20	15	15	20	15
Plastic	×	×	×	×	×	
Stainless steel						×
<b>Pump:</b> Strainer	×	×	×	×	×	×
Diaphragm	×	×			×	
Piston			×	×		×
Pressure vessel	×	×		×	×	
Adjustable pressure relief	×				×	
Non-adjustable pressure relief			×			
<b>Operating lever:</b> Left or right optional	×	×	×		×	
Fixed				×		×
<b>Lance:</b> Brass	×					×
Plastic					×	
Aluminium		×	×	×		
In-line strainer	×	×	×	×	×	
<b>Valve:</b> Brass	×	×	×	×		×
Plastic		×	×		×	
Locking tab	×	×	×	×	×	
<b>Nozzle:</b> Fixed				×		×
Interchangeable	×	×	×		×	
<b>Rated pressure:</b> > 500 kPa			×	×		×
450 kPa		×				
400 kPa					×	
250 kPa	×					

adjusted by a flow control valve which gave a range of pumping rates that were measured in strokes per minute. A pressure gauge was mounted on the lance which had a needle valve at its end to control the flow rate and pressure for a preset pumping rate. Measurements were taken by discharging water into a measuring flask for a specified period.

A team of knapsack operators was monitored in the field to determine the various techniques preferred by the operators under commercial conditions.

Two ULV applicators (Herbi and Birky) were tested for nozzle discharge rates, using different hydraulic heads. The effect of viscosity on liquid flow rate was tested as well. The pumping rate required to operate the clutching mechanism on the turbine of the Birky sprayer was established.

### Results

A comparison of the relevant data of the six sprayers tested is shown in Table 1.

#### Knapsack sprayers

**Cooper Pegler 3 (CP3) Mk 2 (Table 2):** this sprayer has now superseded the CP3 Mk 1. The pressure vessel is accommodated inside the tank with the pressure regulator placed just under the lid. This regulator has two settings of 100 and 200 kPa. It has a smaller diaphragm than the older model which makes it more difficult to obtain high discharge rates at the same pumping rates. The choice of only two pressure settings was found to be inadequate to meet the specifications previously mentioned. The lower pressure relief setting dropped from 105 to 50 kPa while the higher setting caused excessive distension of the pump diaphragm. A maximum pressure of 225 kPa at a zero flow rate was recorded. An intermediate pressure setting of 150 kPa would be an advantage, provided that the relief valve was able to function more efficiently thus maintaining a more uniform pressure.

Table 2

Output obtained from the Cooper Pegler 3 Mk 2 in ml min<sup>-1</sup> for 8 pressure settings at various pumping speeds

Pressure (kPa)	Strokes min <sup>-1</sup>						
	60	65	70	75	80	85	90
50	1 222	1 326	1 434	1 539	1 643	1 748	1 852
75	1 073	1 168	1 263	1 358	1 452	1 547	1 641
100	923	1 008	1 091	1 176	1 261	1 346	1 431
125	772	848	920	995	1 070	1 145	1 220
150	620	686	748	814	879	944	1 010
175	466	523	577	633	688	744	799
200	311	358	405	451	497	543	588
225	156	193	234	270	306	342	378

**Hudson 67367 (Table 3):** the stainless steel tank of the Hudson sprayer and the positive displacement piston pump make it a robust unit. Although the sprayer is capable of high pressure outputs the displacement of the piston is small, and the discharge rate is therefore relatively low. The unit lacks a vessel to absorb fluctuations in pump discharge which may cause an uneven distribution pattern. The nozzle tip is fixed but the supplier will, on request, modify the lance so that interchangeable tips can be fitted.

Table 3

Output obtained from the Hudson 67367 in ml min<sup>-1</sup> for 7 pressure settings at various pumping speeds

Pressure (kPa)	Strokes min <sup>-1</sup>						
	60	65	70	75	80	85	90
100	993	1 079	1 166	1 252	1 339	1 425	1 511
125	982	1 068	1 153	1 238	1 324	1 409	1 494
150	971	1 056	1 140	1 224	1 309	1 394	1 477
175	960	1 045	1 129	1 211	1 296	1 379	1 462
200	950	1 034	1 117	1 198	1 282	1 365	1 447
225	939	1 023	1 106	1 186	1 270	1 352	1 432
250	930	1 013	1 096	1 175	1 258	1 340	1 419

**PTP 20 (Table 4):** this sprayer is similar to the CP3 Mk 1 model because it uses three pressure settings of 200, 300 and 400 kPa. Pressure at each of these settings remained constant, indicating that the pressure vessel is of adequate size. Discharge rates per unit of pressure are high thus the size of the diaphragm pump is adequate to cope with a high application rate.

Table 4

Output obtained from the PTP 20 in ml min<sup>-1</sup> for 7 pressure settings at various pumping speeds

Pressure (kPa)	Strokes min <sup>-1</sup>						
	60	65	70	75	80	85	90
100	1 515	1 629	1 744	1 859	1 974	2 089	2 203
125	1 459	1 568	1 678	1 787	1 897	2 007	2 116
150	1 400	1 504	1 610	1 713	1 817	1 923	2 027
175	1 338	1 436	1 538	1 635	1 735	1 836	1 935
200	1 272	1 366	1 463	1 555	1 650	1 747	1 840
225	1 203	1 292	1 385	1 472	1 562	1 655	1 744
250	1 131	1 215	1 304	1 386	1 472	1 561	1 645

**Hardi RY2 (Table 5)** also uses a diaphragm pump but it has no pressure regulator, so the discharge is directly related to the pumping rate. Of all the sprayers tested, the Hardi RY2 had the highest discharge rate, approaching the required rate of 300 l ha<sup>-1</sup> for the application of a post-emergence herbicide. An additional advantage of the Hardi RY2 is that some of its components are interchangeable with those of the Hardi RY15.

Table 5

Output obtained from Hardi RY2 in ml min<sup>-1</sup> for 7 pressure settings at various pumping speeds

Pressure (kPa)	Strokes min <sup>-1</sup>						
	60	65	70	75	80	85	90
100	1 816	1 974	2 132	2 290	2 447	2 605	2 763
125	1 689	1 836	1 982	2 129	2 275	2 422	2 568
150	1 562	1 698	1 833	1 968	2 103	2 238	2 373
175	1 435	1 559	1 683	1 807	1 931	2 055	2 178
200	1 308	1 421	1 533	1 646	1 758	1 871	1 983
225	1 181	1 283	1 384	1 485	1 586	1 688	1 789
250	1 054	1 144	1 234	1 324	1 414	1 504	1 594

**Hardi RY15 (Table 6)** uses a piston pump which is capable of delivery high pressures. The advantage of this sprayer is that it has a pressure relief valve which will prevent damage occurring at excessively high pressures. The pump is mounted inside the tank and is coupled to an underslung operating lever for left- or right-hand operation.

Table 6

Output obtained from Hardi RY15 in ml min<sup>-1</sup> for 7 pressure settings at various pumping speeds

Pressure (kPa)	Strokes min <sup>-1</sup>						
	60	65	70	75	80	85	90
100	1 472	1 536	1 605	1 674	1 742	1 811	1 879
125	1 475	1 538	1 608	1 677	1 745	1 815	1 883
150	1 472	1 536	1 606	1 676	1 744	1 815	1 883
175	1 464	1 528	1 599	1 670	1 738	1 810	1 878
200	1 451	1 515	1 588	1 659	1 727	1 801	1 869
225	1 433	1 498	1 572	1 644	1 712	1 787	1 855
250	1 410	1 476	1 551	1 642	1 692	1 769	1 836

**Spraying (Table 7):** the locally- designed and manufactured Spraying has a brass piston pump mounted externally on the carrying frame opposite the pressure vessel. Although it is capable of pressures in excess of 500 kPa the discharge rate is relatively low. Pressure fluctuations occur because of the relatively small size of the damper. The tap which isolates the damper vessel was found to be superfluous and if accidentally left in the closed position could damage a pressure gauge if one were installed.

Table 7

Output obtained from Spraying in ml min<sup>-1</sup> for 7 pressure settings at various pumping speeds

Pressure (kPa)	Strokes min <sup>-1</sup>						
	60	65	70	75	80	85	90
100	1 335	1 479	1 624	1 767	1 912	2 056	2 200
125	1 252	1 389	1 528	1 666	1 804	1 941	2 080
150	1 171	1 303	1 436	1 567	1 700	1 832	1 964
175	1 094	1 220	1 348	1 473	1 600	1 726	1 853
200	1 021	1 141	1 263	1 383	1 504	1 624	1 746
225	951	1 065	1 182	1 297	1 413	1 527	1 643
250	884	994	1 105	1 214	1 325	1 433	1 544

The discharge rate of all the sprayers that were tested increased in proportion to an increase in the pumping rate,

and decreased as the restriction at the outlet increased the pressure. The needle valve at the end of the lance simulated the restrictions caused by a nozzle. The application rate of 300 l ha<sup>-1</sup> can be achieved at a walking speed of 60 m min<sup>-1</sup> if the swath width is 1,4 m, and requires a discharge rate of 2,52 l min<sup>-1</sup>. Even at high pumping rates and very low pressures only one of the sprayers achieved this rate.

*Ultra-low volume (ULV) spinning disc sprayers*

Spinning disc sprayers have a cup-shaped disc which acts as a reservoir prior to the liquid being ejected. Before the liquid is sprayed off the disc in a circular pattern by centrifugal force it is sheared into droplets by small teeth situated on the edge of the disc. These droplets follow a curvilinear path until they lose momentum and fall. The droplets travel a maximum distance of 800 mm, giving a swath width of about 1 600 mm (Mathews').

At present no herbicides for use in the sugar industry are registered for application by ULV spinning disc sprayers but there are important reasons for testing these techniques, for example the benefits of less water cartage and easier spraying on steep slopes.

**Herbi:** this sprayer is driven by an electric motor powered by six 1,5 V 'C'-type torch batteries. The motor's speed is kept constant by a centrifugal switch mounted on the armature. The batteries are positioned in the carrying handle to counterbalance the weight of the sprayer components. Three different types of batteries were tested for longevity and the results are shown in Figure 1. The cut-off point was where the batteries could no longer sustain a motor speed of 1 600 rpm. The alkaline batteries were found to last approximately twice as long as the standard batteries.

The chemical mixture is stored in a 2 l container and is fed by gravity to the nozzle which is mounted above the disc. Because of the low discharge rate ULV applicators use highly concentrated formulations and require smaller containers than knapsack sprayers. It would be beneficial to use larger containers to reduce the downtime required to fill them. Test were conducted to determine the effect of using larger containers on the overall discharge rate from the nozzle.

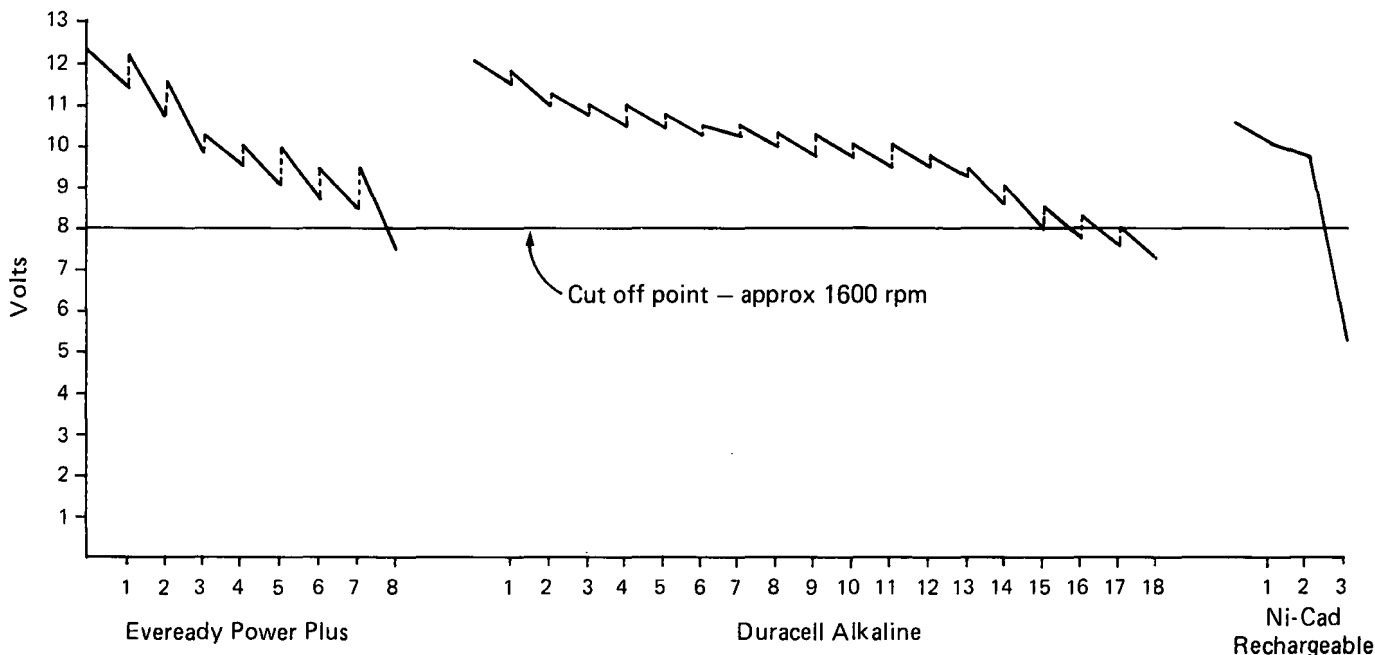

FIGURE 1 Volts under 2 amp load vs days using the Herbi sprayer (average 5 h d<sup>-1</sup>).

A reduction in flow rate occurred as the hydraulic head diminished. The effect was the same with each nozzle but the reduction was less pronounced for the smaller orifice sizes. A predictable reduction in output was noticeable as the viscosity increased. Diesel fuel was used as the test medium and was compared with water. The effect on flow rate with liquids of high viscosity will be similar. The reduction in flow rate in  $l\ h^{-1}$  with diminishing hydraulic head is shown in Figure 2.

A float valve in the feedline to the nozzle would give a constant flow rate which would be represented on the graph by a horizontal straight line. The line in Figure 2 is curved however because the valve was progressively tipped slightly forward during the test. If the valve were mounted in a vertical position under the tank rather than at the end of the lance, a more even flow rate would result.

The Herbi sprayer is supplied with four different sized nozzles and by changing these nozzles, different application rates were achieved.

**Birky:** the Birky sprayer is similar to the Herbi sprayer in that it also operates on the spinning disc principle. A knapsack contains a reservoir for the chemical as well as a manually operated air pump for driving the turbine. Air is forced down the carrying tube attached to the knapsack unit, through the turbine which is coupled to the shaft of the sprayer disc. If the air pressure becomes too high the turbine is disengaged from the disc drive by a centrifugal clutch. When the air flow is sufficient to maintain adequate rotational velocity air is emitted through a whistle valve to indicate that the disc is spinning at the correct speed.

The Birky sprayer is robust and can carry more liquid than the Herbi sprayer, but because the nozzle is gravity fed the Birky sprayer is also subject to changing discharge rates as the level in the tank drops.

## Discussion

Spraying techniques are probably the most important and also the most neglected aspect of the spraying operation. The object of the spraying operation is to apply the chemicals as cost-effectively as possible. To do this, accurate calibration of the equipment and consistent application techniques are necessary.

The results of the survey showed that large variations in the application rate can occur if the operators are not trained. The operators should be instructed to use their equipment in the least physically tiring way, while at the same time spraying at a consistent rate. It may be easier for the operators to pump at a pace which is synchronous with their stride. In other words, on each alternate step the pumping lever is moved through one pumping stroke. Walking speed will vary according to the terrain, so calibration of the sprayers should be done on the terrain which is to be sprayed and the walking pace matched to a rate that can be sustained for long periods. The lance must be held at a constant height according to the required swath width and the pumping stroke should, at all times, be at a maximum to avoid variations in output. When several operators are working as a group it is generally easier for them to follow the pace and pumping rate of one of them, so that calibration need only be done for that person provided that they are all using identical equipment.

### Suggested modifications

If the Herbi ULV sprayer were to be fitted with a larger tank, a regulator valve would need to be mounted in the feedline to avoid the problems associated with a diminishing hydraulic head. This principle was demonstrated using the float chamber of a carburettor, and a prototype regulator was subsequently constructed to accept a variety of non-volatile chemicals, especially those of the wettable powder type.

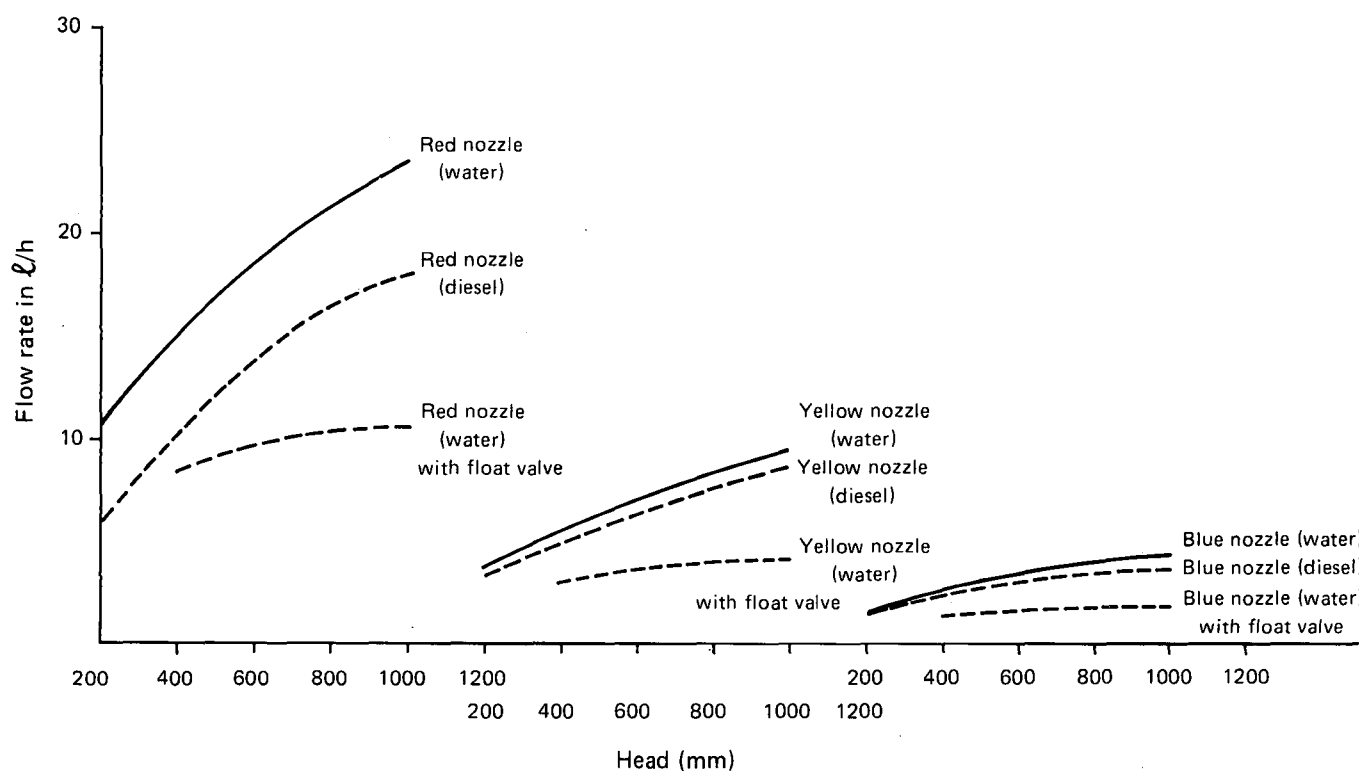

FIGURE 2 Flow rate vs head for 3 nozzles at 2 different viscosities, both with and without a float valve, using the Herbi sprayer.

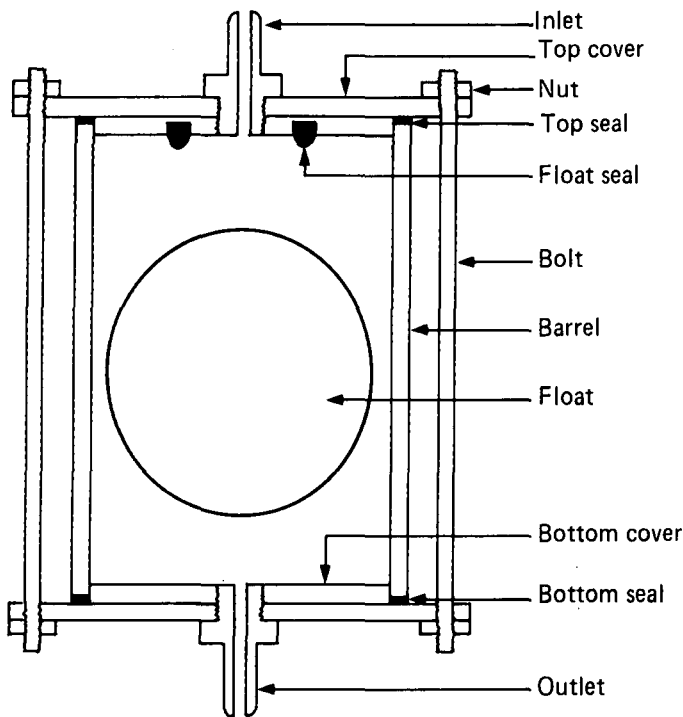

FIGURE 3 Cross-sectional diagram of the float valve.

It is possible that the physical demands when using knapsack sprayers could contribute to inefficient application of expensive chemicals. To reduce this loss or expense, a mechanically pressurised sprayer was developed to eliminate the effort involved in manual pumping and to maintain as far as possible the required output for the spraying of post-emergence herbicides. The compression knapsack (CK) sprayer (Figure 4) consists of two stainless steel tanks mounted on either side of a compartment which houses a small electric compressor of the type used to inflate vehicle tyres, and a 14 amp hours motor-cycle battery. The tanks hold 20 l and are pressurised by the compressor. Once the optimum pressure is reached, the compressor is switched off by a preset pressure sensing switch. The chemical is emitted through a standard lance which contains a filter and a shut-off valve in its handle.

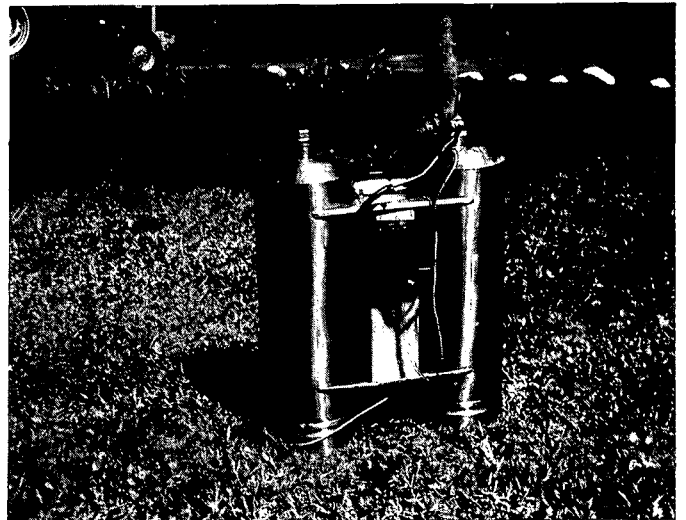

FIGURE 4 The compression knapsack (CK) sprayer.

### Conclusions

Recent increases in the cost and complexity of chemicals have resulted in improvements in the design of knapsack sprayers as well as the introduction of the ULV and electrodyne applicators. Much research is conducted into chemical development and applicator technology, but the value of these efforts may be lost if application techniques are ineffective.

### Acknowledgements

The time and advice of the representatives of the commercial companies who lent the Agricultural Engineering department the equipment for testing are gratefully acknowledged.

### REFERENCE

- 1 Matthews, GA (1979). *Pesticide application methods*. London, Longmans: 93-94.