

# SYRUP CLARIFICATION IN RAW SUGAR MILLS

By P. W. Rein, and M. G. S. Cox  
*Tongaat-Hulett Sugar Limited, La Lucia*

and G. Montocchio  
*Tongaat-Hulett Sugar Limited, Felixton*

## Abstract

The results of a laboratory investigation into clarification of syrup by flotation are described, as well as a comprehensive test programme on a full-scale unit installed subsequently at Empangeni mill. The benefits to be achieved from syrup clarification have been established. Factors influencing the performance of syrup clarification are described, which have proved useful in the design of further full-scale units. Preliminary results from a syrup clarifier installed at the new Felixton mill are given.

## Introduction

The mill at Empangeni always suffered from poor cane quality. This led to extreme difficulty in producing VHP quality sugar and to highly viscous massecuites, which meant that exhaustion of final molasses was also poor. Juice clarification was generally poor, and although some additional processes such as high pH liming and sulphitation were looked at in the laboratory, there was an understandable reluctance to make the processing sequence any more complicated or more expensive.

Clarification of syrup by settling is not possible because of the high density and viscosity of syrup. However, flotation clarification is a well-established process in both sugar refining and water treatment. In this process, very fine suspended matter which will not settle can be floated off. The mechanism involves physical capture of the air bubbles within the flocs and intramolecular attractions across the air/liquid interface. Scum can be floated off with bubbles in the clarifier. The degree of separation achieved depends on the surface properties of the solid particles.<sup>1</sup>

Considerable work was done in South Africa on flotation clarification of juice, both under vacuum and under atmospheric conditions. The process showed some considerable promise and results were reported by the Sugar Milling Research Institute (SMRI).<sup>2</sup> However, the scum formed was apparently not as stable as that obtained in syrup clarification.

In 1974, a Tate & Lyle syrup clarification process was put into operation at Noodsberg. This showed that the process led to an improvement in sugar quality and a reduction in massecuite viscosity, but no boiling house improvement was evident.<sup>3</sup> Since sugar quality was not a concern at Noodsberg at that time, this process was discontinued. Similar results were obtained at Belle Vue sugar mill in Mauritius.<sup>4</sup> Sugar quality was improved and the effect on the downstream refinery process was extremely marked. Massecuites were found to be less viscous and easier to cure, but they were not able to show the benefit of the process on final molasses purities. They reported that the process led to a small increase of 5% in colour, but a reduction in turbidity of the syrup of 67%.

Following the work done on a syrup clarifier in Honokaa, Hawaii,<sup>5</sup> it appears that flotation clarification can be operated without the addition of phosphoric acid. This reduces considerably the cost of the process and it was decided to look at this in the laboratory.

A comprehensive laboratory investigation was undertaken, which showed very promising results as regards turbidity removal and viscosity reduction. This laboratory investigation established some of the design parameters necessary for the design of a full-scale unit. This was subsequently put in at Empangeni and operated for two years before the mill was closed down. During this period, the syrup clarifier showed significant benefits as regards sugar quality and massecuite viscosity. Subsequently, when the new Felixton mill was built, a syrup clarifier was installed there as well. Operating experience at both Empangeni and Felixton has given a better insight into the process and has enabled it to be optimised.

## Results of laboratory work

A laboratory test was devised which involved rapid stirring of syrup in a water bath at 85°C for 3 minutes. The stirring arrangement was such that air was entrained into the syrup to saturate it with air. Polyelectrolyte was added and the syrup was then left standing for 20 minutes.

It was found that turbidity reductions of 80 to 90% could be consistently obtained. The measurement of turbidity in syrup was found to be affected by a number of different factors, including brix of the solution being measured. The method in the laboratory manual for South African sugar factories was found to be unacceptably sensitive to small changes in pH. Therefore the procedure given in Appendix 1 was developed and used in this work.

Since the initial series of tests were carried out, a large number of laboratory tests have been carried out on a variety of syrups from a number of factories in South Africa and Zimbabwe. Some slight variations in turbidity removal are noted, due probably to the different natures of the particulate material. Nevertheless, turbidity removals have always been in the range of 80 to 95%.

These laboratory trials, however, showed that there was no significant purity improvement and that the amount of ash removed was very small. In addition, no improvement in syrup colour was measured.

These tests were done without the addition of phosphoric acid and lime. The effect of these additional chemicals on turbidity removal was investigated in detail. Results are shown in Table 1, but the general conclusion is that the addition of phosphate and lime did not improve removal of impurities or colour and actually gave worse turbidity removal. This indicated clearly that the simple clarification without the addition of any additional chemicals, other than polyelectrolyte, would be a viable proposition.

Laboratory trials showed the optimum flocculant dosage to be around 10 to 15 ppm. These results are shown in Figure 1, and indicate that any higher dosage figures do not make any material improvement. No effect of different type of polyelectrolytes was established initially. Later tests, however, showed that Talosep A3 and Separan gave better results than Magnafloc LT27. In general, it has been found that the

polyelectrolytes with a higher degree of hydrolysis do give better results.

**Table 1**

Effect of phosphoric acid/lime addition on turbidity removal

Phosphate dosage (mg/l)	Av. turbidity removal %
50	88,2
100	78,7
200	77,9
300	80,5
400	62,6
500	33,7
600	33,9
800	39,0

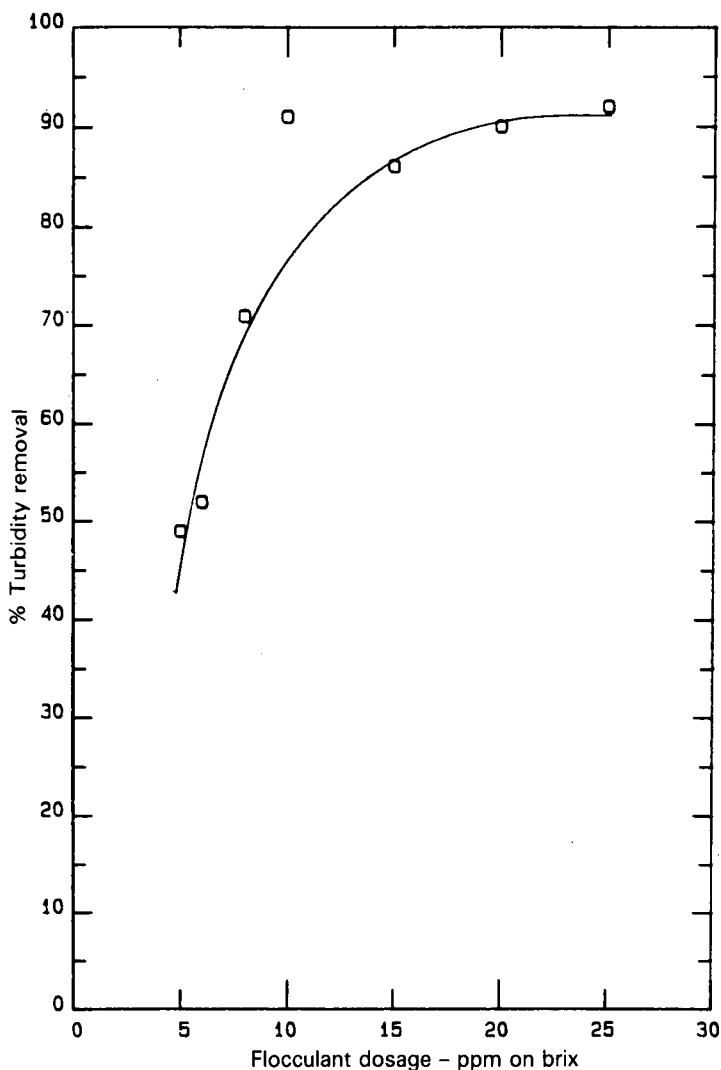

**FIGURE 1** Turbidity removal measured in the laboratory as a function of flocculant dosage.

Temperature was found to have a significant effect on turbidity removal. This is shown in Figure 2, which indicates that a progressive improvement is obtained up to 85 °C, at which point the effect of temperature levels off.

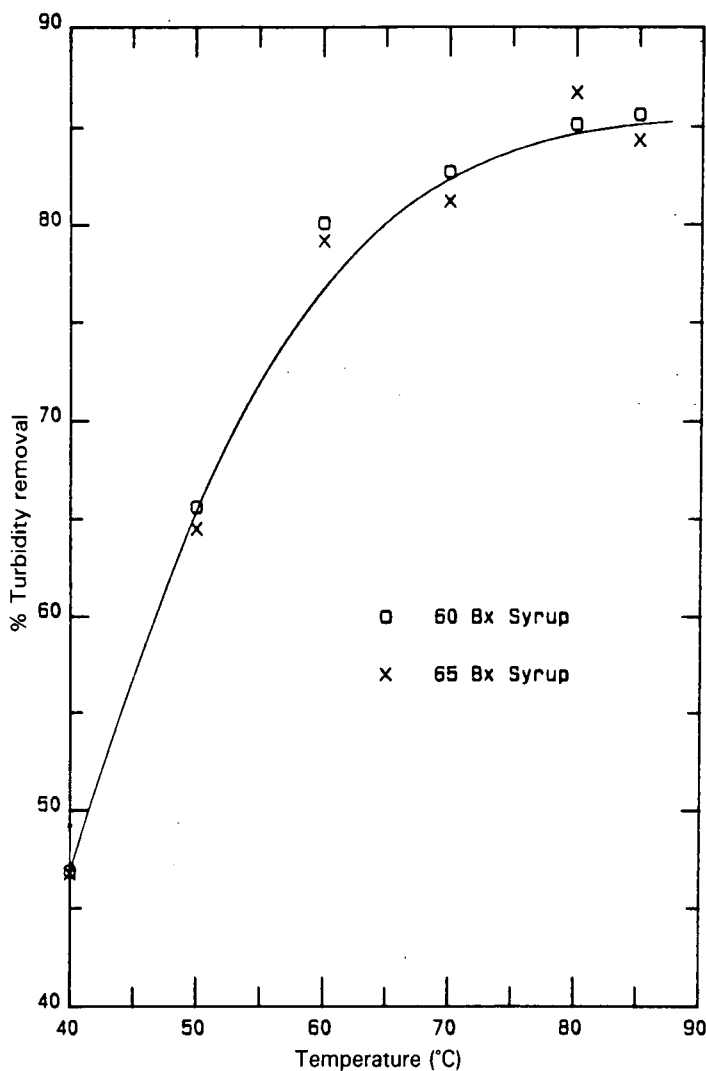

**FIGURE 2** Effect of temperature on turbidity removal.

From Figure 2 it can also be inferred that turbidity removal is independent of the brix and viscosity of the syrup. The viscosity of the 65 ° brix syrup is about 50% higher than that of 60 ° brix syrup used in the results shown in Figure 2. Clearly, therefore, viscosity values, within the range encountered, do not have any effect on this process and the better results at higher temperatures are not due to viscosity reduction, but due to the effect on the formation of flocs or on the intramolecular attractions across air/liquid interfaces. Further tests confirmed that liquid viscosity does not affect the removal process.

Both clarified and unclarified syrup were subjected to laboratory boilings. The viscosities of the molasses produced were measured and the results are shown in Figure 3. The viscosity of the clarified syrup and molasses after boiling was lower by up to 25%.

The effect of settling time in the laboratory test was investigated. This showed that there was a tailing-off of % turbidity removal between 10 and 15 minutes, and that a retention time above this was unlikely to lead to improved results.

It has been found in refinery phosphatation that it is necessary to employ dissolved air flotation rather than the simpler dispersed air flotation process.<sup>6</sup> Again, laboratory trials indicated that there was no advantage in dissolved air flotation and, if anything, the dispersed air flotation gave better results.

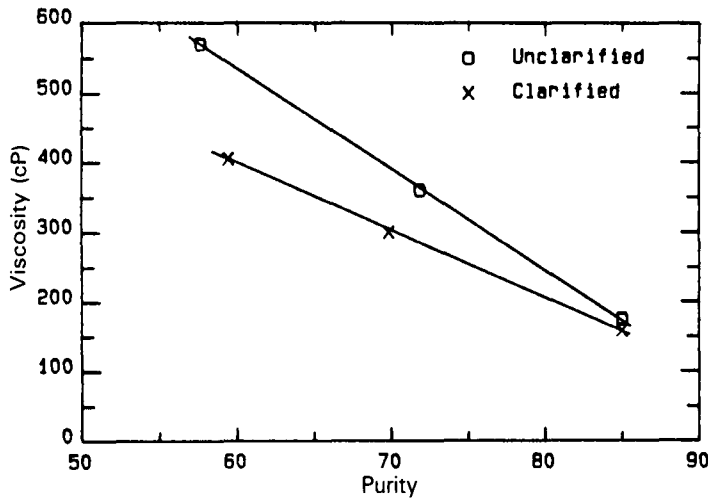

FIGURE 3 Viscosity of syrup and molasses (at 73 brix and 40 °C) with and without syrup clarification.

These laboratory tests were encouraging and established some of the design parameters necessary for a full-scale plant. A syrup clarifier was therefore designed and installed at Empangeni mill.

### Design of Empangeni syrup clarifier

#### Process conditions

Laboratory work showed that there would be no necessity to reduce brix of the syrup. In refinery phosphatation, Saranin<sup>6</sup> has stated that it is not practical to operate a flotation process with the liquor viscosity greater than 10 cP. Laboratory work showed that there was no effect of viscosity even up to viscosities of 25 cP at 85 °C.

The laboratory work showed clearly that temperature should be increased to 85 °C. A spare shell and tube heater was available to do this duty.

On the basis of the laboratory work, it was considered that an average residence time of 20 minutes would be sufficient. The system put in at Empangeni allowed for a 25 minute residence time, assuming that remelt was added to syrup before the clarifier.

The effect of pH was also investigated in the laboratory and no significant effect was established. Thus no allowance for pH adjustment was made.

#### Clarifier design

In designing the clarifier, attention was given to a number of different aspects. Firstly, the hydraulic design requires that incoming liquid should be fed in with minimum disturbance

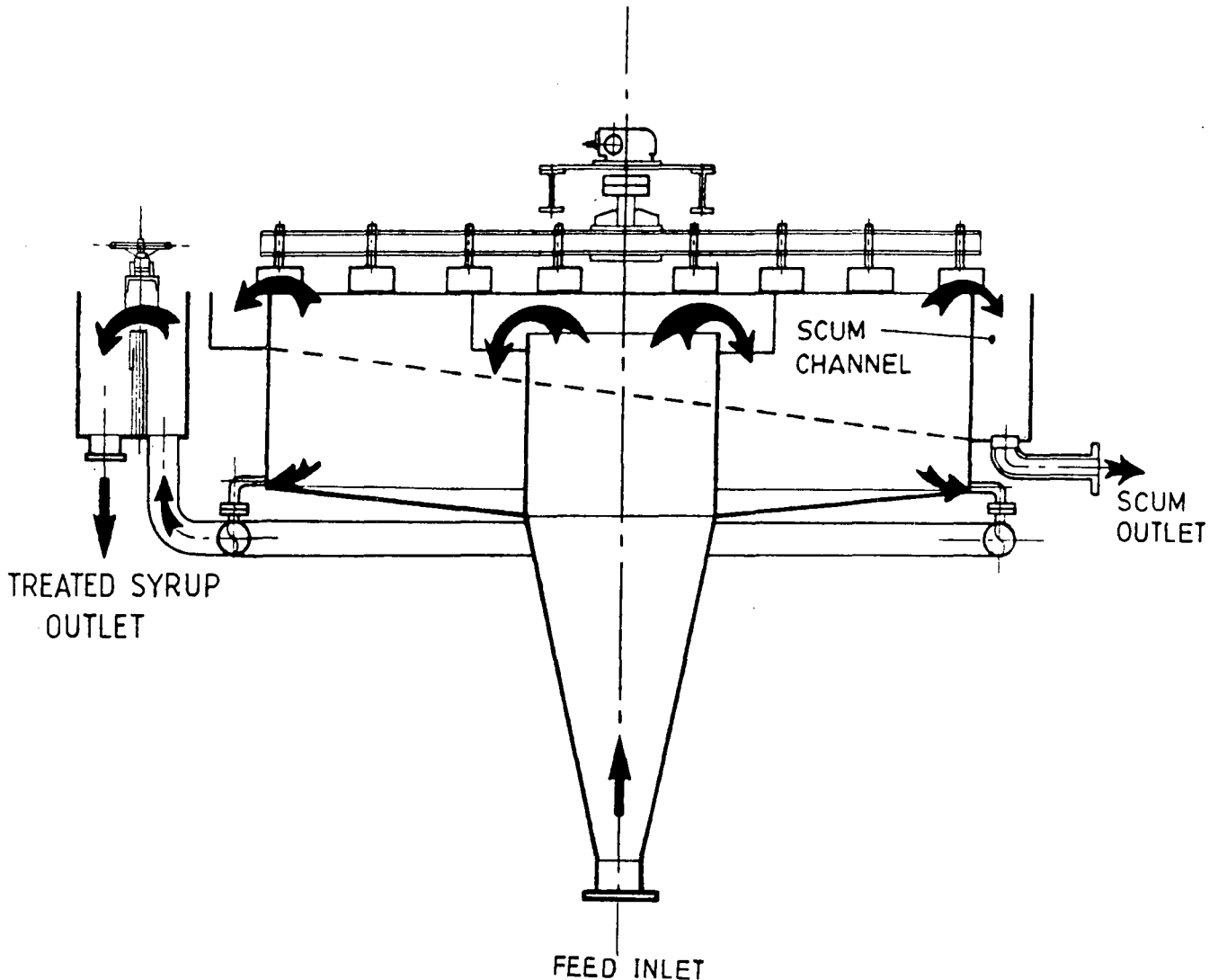

FIGURE 4 Sketch of the syrup clarifier installed at Empangeni.

at the correct density level, with the minimum of inlet energy so that turbulence is not created. The depth of the clarifier is important only in providing sufficient height to be able to maintain separate froth and clear liquid zones. Flotation cells in refineries have been built in depths ranging from 0,25 to 1,5 m and Saranin<sup>6</sup> suggested that a depth of the order of 0.9 m could be optimum. What is more important he suggests, is that sufficient cross-sectional area should be provided to facilitate separation of the scum and that the depth should be fixed by the required retention time.

The Empangeni clarifier was built with an average depth of 1,5 m and a diameter of 4,1 m. A sketch is given in Figure 4. Ideally, plug flow of syrup should occur so that there are no stagnant zones of long residence time. For this reason, the offtakes were located at the extremities of the clarifier furthest from the feed inlet.

Providing these requirements are adhered to, it is not important whether a round or rectangular clarifier is used. In this case, a circular clarifier was used with a rotating scraper to scrape the scum off the edge of the clarifier and into a launder.

In order to allow the scum a certain degree of thickening before being removed, the liquid level is maintained slightly below the sides of the clarifier. The variable level control on the clear liquid outlet was provided to enable control of the thickness of the scum layer to be regulated.

*Aeration of the syrup*

There are three methods of flotation currently in use.<sup>1</sup> The first is dispersed air flotation where gas bubbles are generated by introducing the gas phase through a revolving impeller or through porous media. Bubble size is of the order of 1 000

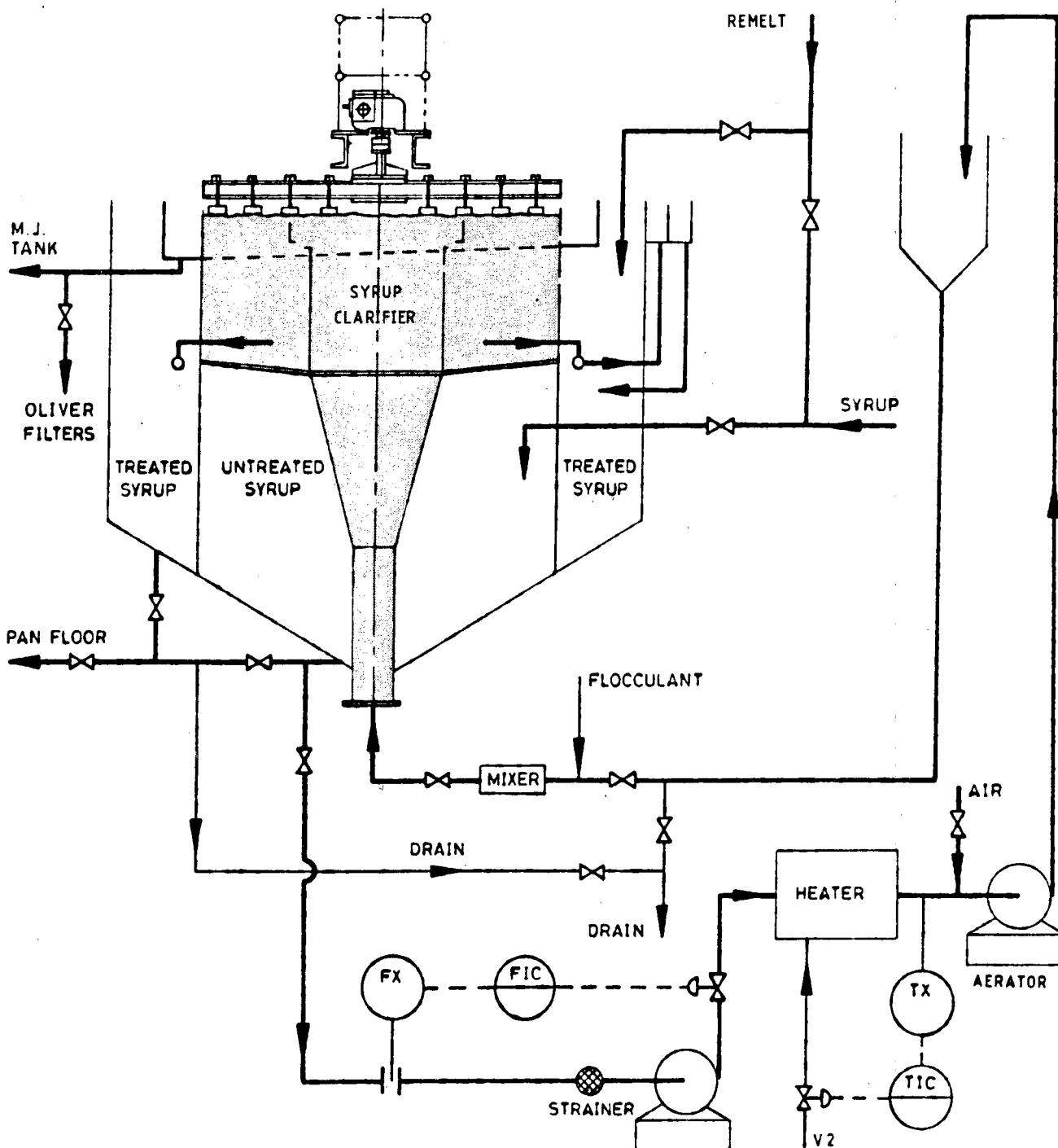

FIGURE 5 Flow diagram for Empangeni syrup clarification.

microns in diameter. The second is dissolved air flotation, where bubbles are produced as a result of the separation of the gas from a supersaturated solution. Average bubble sizes are smaller and range from 70 to 90 microns. The third method is to produce gas bubbles by electrolysis. Under these circumstances, the bubble size can be smaller than 50 microns.

The third method mentioned above was found to be impractical in the laboratory. It might be expected that dissolved air flotation should be more efficient than dispersed air flotation in that the bubbles are smaller and better dispersed within the liquid. However, the simple aeration procedure used here must be classified as dispersed air flotation.

Dispersed air flotation is commonly achieved by injecting air into the suction side of a pump operating at high speed. However, this process has its limitations. If more than about 8% by volume of air is injected, air binding will occur in the pump.<sup>1</sup> In addition, only about 40% of air injected into the suction of a pump is dispersed in the liquid, and the remainder consists of large bubbles which cause undesirable turbulence; thus it was necessary to install a small air release tank immediately before the clarifier.

The requirements of the system should be to add the correct amount of air to the suspension as well as to ensure a good dispersion of bubbles throughout the suspension.

Initially, air was introduced into a pump running at 2-pole motor speed. Better results were subsequently achieved when a separate aeration pump was introduced. This was specially designed with radial fins and blades in the volute

to ensure considerable shear, thus achieving the necessary air dispersion.

*Empangeni syrup clarifier system*

The flow diagram of the system used is shown in Figure 5. The clarifier itself was installed in the top of a syrup tank which was previously a juice clarifier and therefore very much larger than necessary. This tank was divided in two by a concentric partition to separate treated and untreated syrup. This led to a low cost installation, the total costs for the whole system being of the order of R80 000.

Syrup was pumped at a steady flow rate through a flow control valve and a heater in which the syrup was heated to about 85°C. This was then aerated in a special aerator where air was metered in through a rotameter into the suction of the aerator pump. Following the air release tank, flocculant was added to the aerated syrup and gently mixed into the syrup through the specially designed in-line mixer. This was designed to induce good dispersion of the flocculant within the liquor without significant shear which could lead to breakdown of the floc. Finally the syrup entered through a central feed pipe, the diameter of which increases as the syrup enters to reduce inlet velocities to a minimum.

**Operating Results**

The turbidity removal achieved over the two seasons for which the syrup clarifier operated, are shown in Figures 6 and 7. Initially, turbidity removal was low, but it can be seen how it increased as design and operational problems were

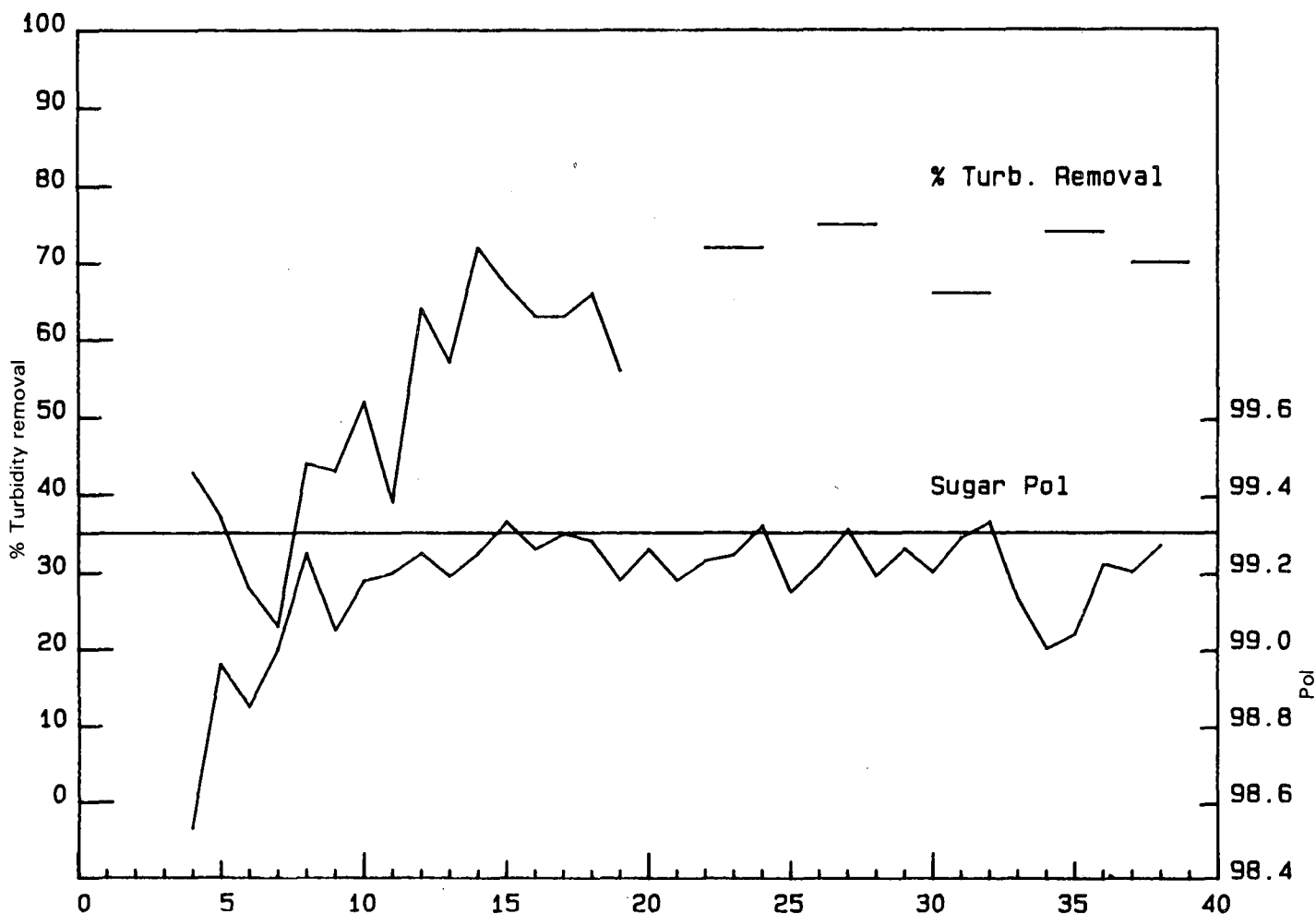

FIGURE 6 Operational results at Empangeni, 1981/82 season.

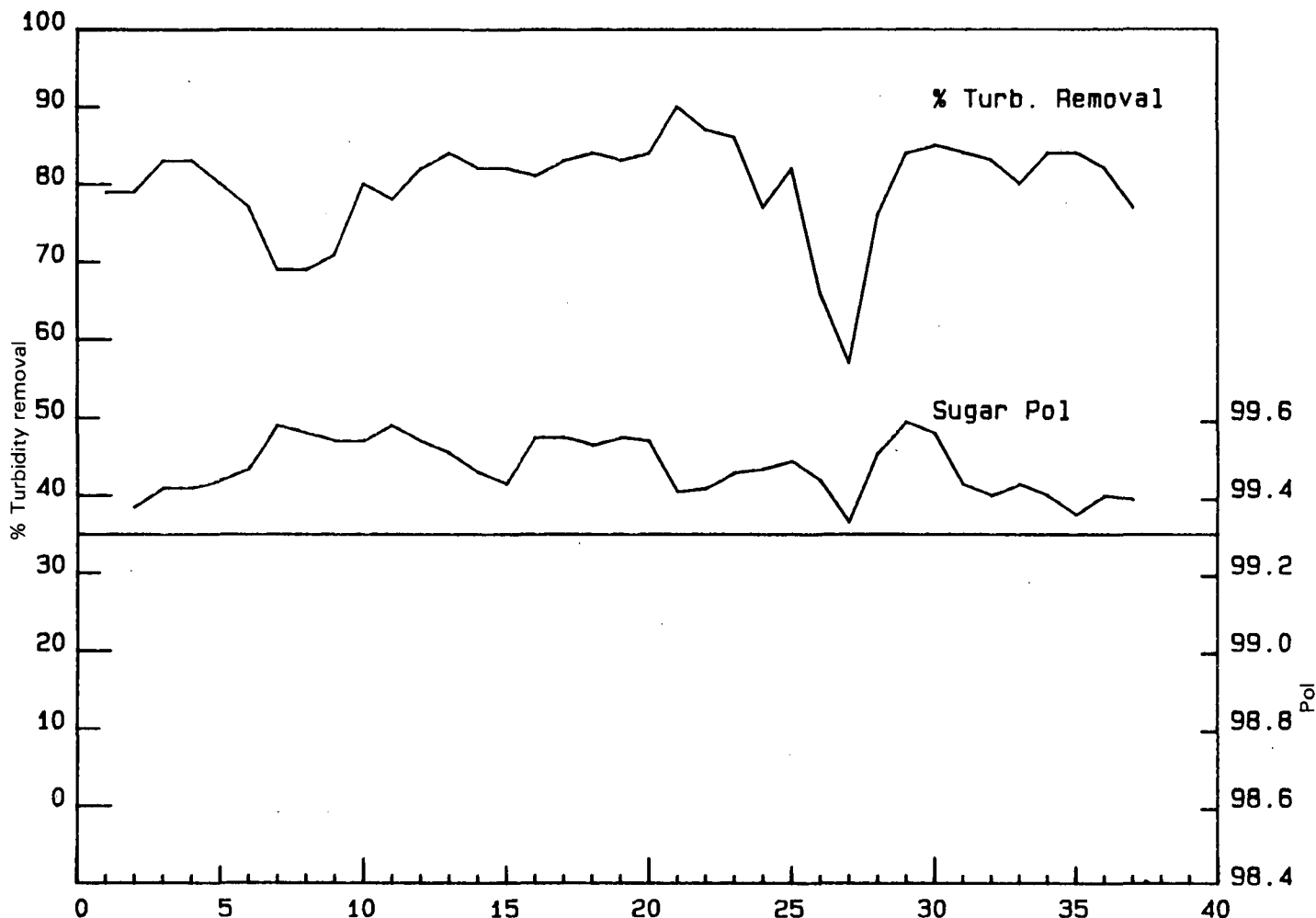

FIGURE 7 Operational results at Empangeni, 1982/83 season.

sorted out. The major improvement in turbidity removal was achieved when the new aeration system was installed.

The poor performance shown in weeks 25 to 27 in Figure 7 represents a period when flocculant dosage was dropped from 15 to 7,5 ppm on brix.

The only other change which was made to the system was to modify the syrup offtakes. The original syrup clarifier had treated syrup draw-offs from around the bottom of the outer circumference of the clarifier. The tracer test indicated a peak in residence time distribution well below the theoretical and a long tail indicative of bypassing and semi-stagnant regions. The offtakes were modified so that the effective offtake area was from the middle of the bottom of the clarifier. This led to a significantly improved residence time distribution which is shown in Figure 8. A further tracer test undertaken without the central feed tube in the clarifier also indicated very much worse performance.

A major test programme was carried out in 1981, which involved running the process for periods of two weeks in operation and two weeks off, in order to assess the effect not just on sugar quality but on boiling house recovery as well. These periods of on and off operation are evident in Figure 6. In order to assess the effect on boiling house recovery, the first week of each two-week period was rejected and the results of the second week of each two-week period only were considered. However, in view of the considerable variations in conditions over the long period of the test, the small variations which were being looked for in boiling house improvement could not be established. However, a significant improvement in the sugar quality was obtained. The

results of this test period are shown in Table 2. A significant decrease of 15% was found in colour and gums of affinated sugar. A 15% reduction in the ash of the affinated sugar was also measured, but the difference was not established statistically with a high level of confidence. These results were achieved even though the syrup clarifier was achieving only around 70% turbidity removals during the period of the trial. In practice, the effects of the syrup clarifier operation have been seen to be extremely marked.

Table 2

Analysis of affinated sugar during syrup clarifier tests at Empangeni - 1981

Analysis	Clarifier on		Clarifier off		t	Degrees of freedom	Significance level
	Mean	Std. dev	Mean	Std. dev			
Colour a*c 560	0,22	0,058	0,26	0,039	-1,81	17	95%
Ash	0,09	0,019	0,10	0,029	-0,91	17	NS
Gums	950	149	1100	102	-2,63	17	99%
Aff. sugar pol	99,78	0,118	99,72	0,193	0,84	17	NS
VHP sugar pol	99,30	0,092	99,27	0,160	0,49	14	NS

Analysis of data for A-masseccite exhaustion and the purity rise on A-curing show better results with the syrup clarifier in operation, indicating that less washing was necessary to achieve the required VHP sugar pol.

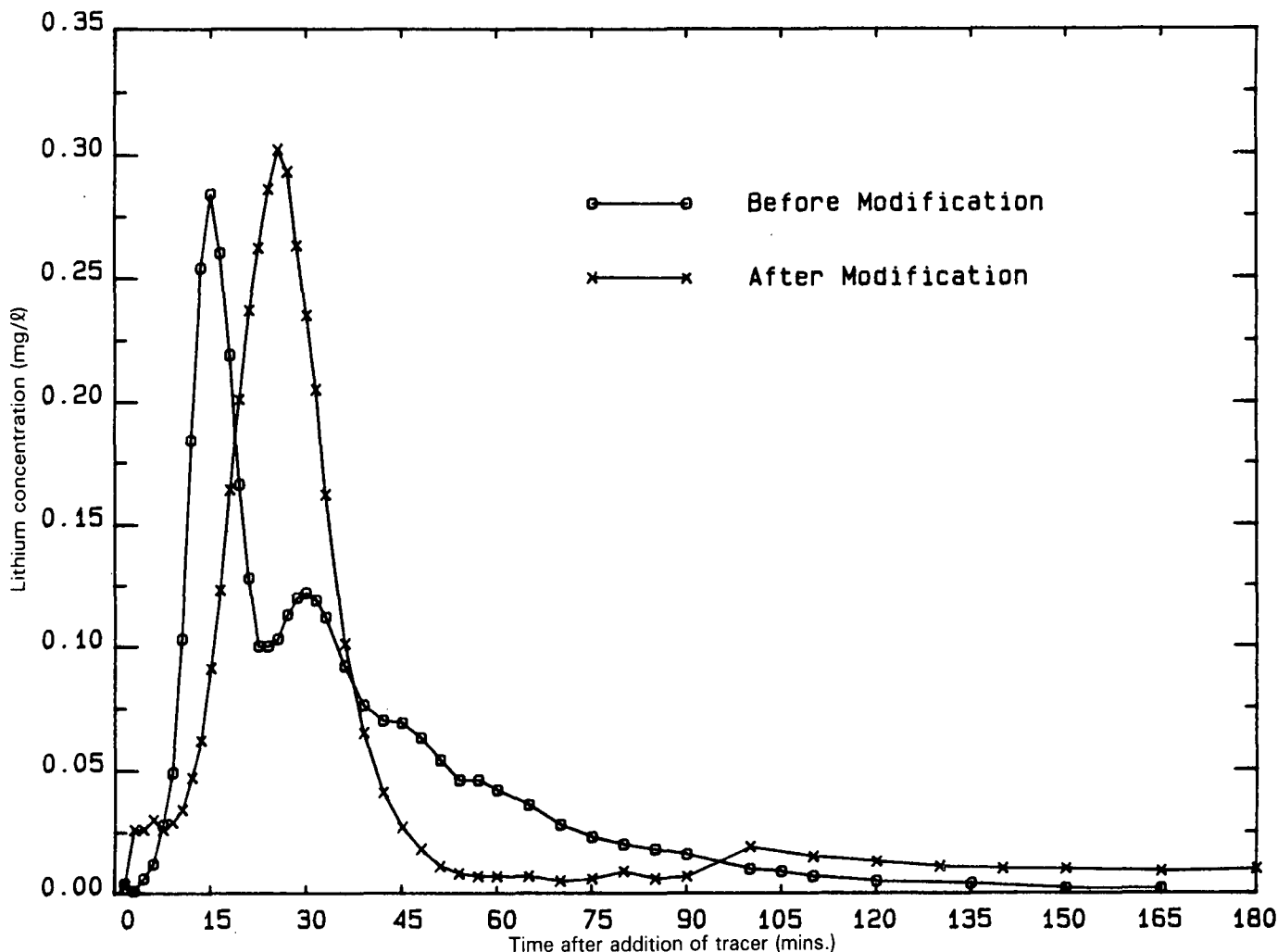

FIGURE 8 Residence time distribution of syrup measured in the Empangeni syrup clarifier before and after modification to the offtakes.

Boiling down tests were also undertaken on the second week molasses composite samples. The final target purity from these tests was not found to be significantly different.

Although no significant difference in target purity difference was recorded, a higher molasses brix was generally obtained with the clarifier on. The reason for this is evident in Figure 9, which shows that the operation of the syrup clarifier gave a decrease in final molasses viscosity ranging from 25% at high solids, down to less than 10% at low solids content. Thus the mill had been able to take advantage of the lower viscosities either by boiling higher brix massecuites or using less steam and water on the centrifugals.

A series of factorial tests was carried out in 1982, to investigate the effect of air quantity, temperature and electrolyte dosage on performance. Provided the minimum quantity of air was introduced (of the order of 0,04 m<sup>3</sup>/m<sup>3</sup> syrup), the effect of quantity of air seemed to be insignificant. However, temperature was found to have a very significant effect, as established in the laboratory. Also, better results were obtained with 30 ppm flocculant on brix, rather than 10 ppm, although this difference disappears at higher temperature. These effects are shown in Figure 10.

In general, it was found that the syrup clarifier was always able to achieve the same degree of turbidity removal as that obtainable in the laboratory. Subsequently, it has been found that this provides a useful check as to whether the plant syrup clarifier is performing as well as it should by comparison with the results obtainable in the laboratory.

The scum from the syrup clarifier was generally returned to mixed juice. Scum quantity varied considerably, but was

of the order of 5% by volume. A trial was undertaken where the scum was returned to the filter muds. However, this overloaded the filters and led to a higher pol loss in cake and so this was subsequently discontinued.

Empangeni mill was closed down during 1983. Some performance results are given in Table 3. The syrup clarifier enabled Empangeni to produce consistently good quality sugar meeting VHP specification and for the first time in many years to achieve molasses exhaustion results comparable with the best mills in the industry. Since Empangeni cane was to be delivered to the new Felixton mill, it was felt to be essential to install a syrup clarifier at Felixton II as well.

Table 3  
Factory performance results at Empangeni

	1980/81		1981/82		1982/83	
	EM	Industry	EM	Industry	EM	Industry
Sugar pol	99,32	99,40	99,17	99,38	99,45	99,35
Export sugar:						
Colour a*c 560	0,49	0,30	0,47	0,26	0,29	0,26
Ash	0,19	0,12	0,18	0,15	0,16	0,16
Boiling House						
Recovery	85,0	87,5	85,7	87,7	86,5	87,6
Tons sugar -						
Refinery	66 300		93 325		50 718	
Export	6 246		7 125		66 088	
MJ Purity	83,3	84,8	84,2	85,7	84,0	85,1
RS/Ash ratio	1,0	1,1	0,9	1,1	0,8	0,9
TPD	9,4	6,7	5,5	4,2	3,9	3,9
Syrup clarification	No	-	Partial	-	Yes	-

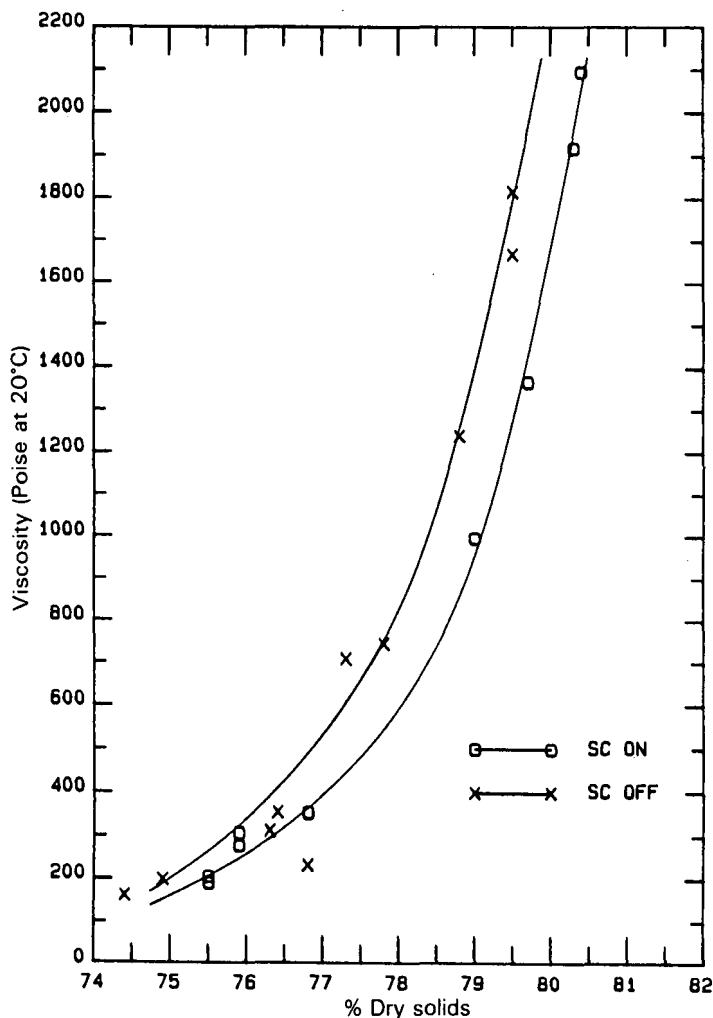

FIGURE 9 Final molasses viscosities measured at Empangeni during the 1981/82 season.

### Further Experience with Syrup Clarification

A small syrup clarification system was installed in the old Felixton mill, shortly before it also closed, during a period of extremely poor cane quality occasioned by a drought. This was done quickly and at low cost, but since scum removal was purely by overflow and not with the aid of the scraper mechanism, results were somewhat below that achieved at Empangeni.

A 45 m<sup>3</sup> syrup clarifier, based on a 20 minute residence time, was installed at the new Felixton mill. Details of the design and installation were very similar to that employed at Empangeni. However, a separate polyelectrolyte system was installed so that different flocculants can be used for juice and syrup clarification. In addition, a plate heater was installed to heat the syrup up to 85°C immediately before the clarifier. Unfortunately this plate heater has been plagued by blockage of the channels in the plates, due to the fact that small quantities of fibrous bagasse are present in the syrup and form a mat in the inlet ports, effectively blocking the heater. Thus, for most of the time, the syrup clarifier has operated at a temperature of around 58°C.

Figure 11 shows turbidity removal achieved at Felixton II during a period when attempts were made to optimise the operation of the clarifier. Once attention was given to proper dosing of polyelectrolyte, turbidity removals of 65 to 70% were achieved. Laboratory tests during this period indicated that at 85°C, turbidity removal should be 85%. The turbidity achieved in the plant is only 80% of that obtainable

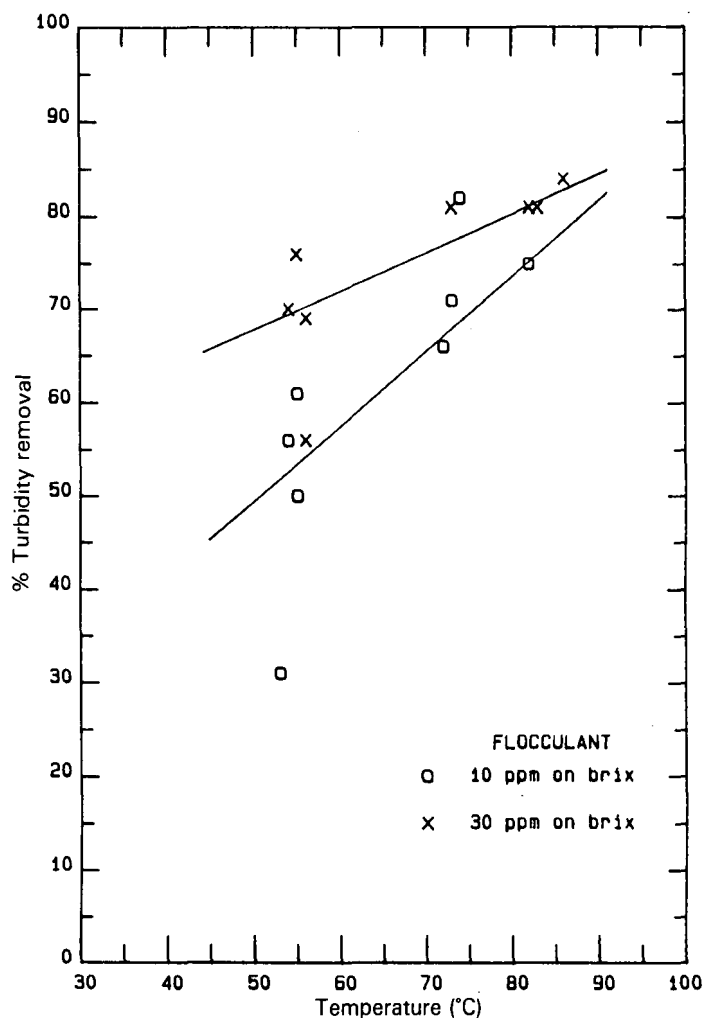

FIGURE 10 Effect of temperature and flocculant dosing level on performance of the Empangeni syrup clarifier.

at 85%. Data in Figure 2 and Figure 10 indicate that at 58°C, turbidity removal should be between 85 and 90% of that achievable at 85°C. Thus it appears that the lower turbidity removal which had been achieved at Felixton is due largely but maybe not entirely to the lower temperature.

Various options for screening before the plate heater have been investigated at Felixton, and during the coming season it is anticipated that temperatures will be up at 85°C. In spite of the fact that turbidity removal is lower than it should be at Felixton, no problem has been experienced in making VHP specification sugar, even when mixed juice purities have been as low as 75. Although it is believed that the continuous A-pans also assist in reducing sugar colour, the syrup clarifier has ensured that sugar quality has been consistently acceptable. During a period of two weeks, the syrup clarifier was shut down to see whether it had any influence on undetermined loss. No effect could be detected, but there was an immediate effect on sugar quality. Sugar colour recorded at the Hulett Refinery during this period is shown in Figure 12. The increased colour can be shown to be statistically significant at the 99% confidence level.

Experiments have also been undertaken at Felixton to investigate the method of air addition. A simple sparger instead of the dispersing air pump has been investigated. Although the simple sparger appears to give the same kind of turbidity removal, the appearance of the scum suggests that the aeration pump system should give much better results. This will be repeated once higher temperatures have been achieved, and on different qualities of syrup.

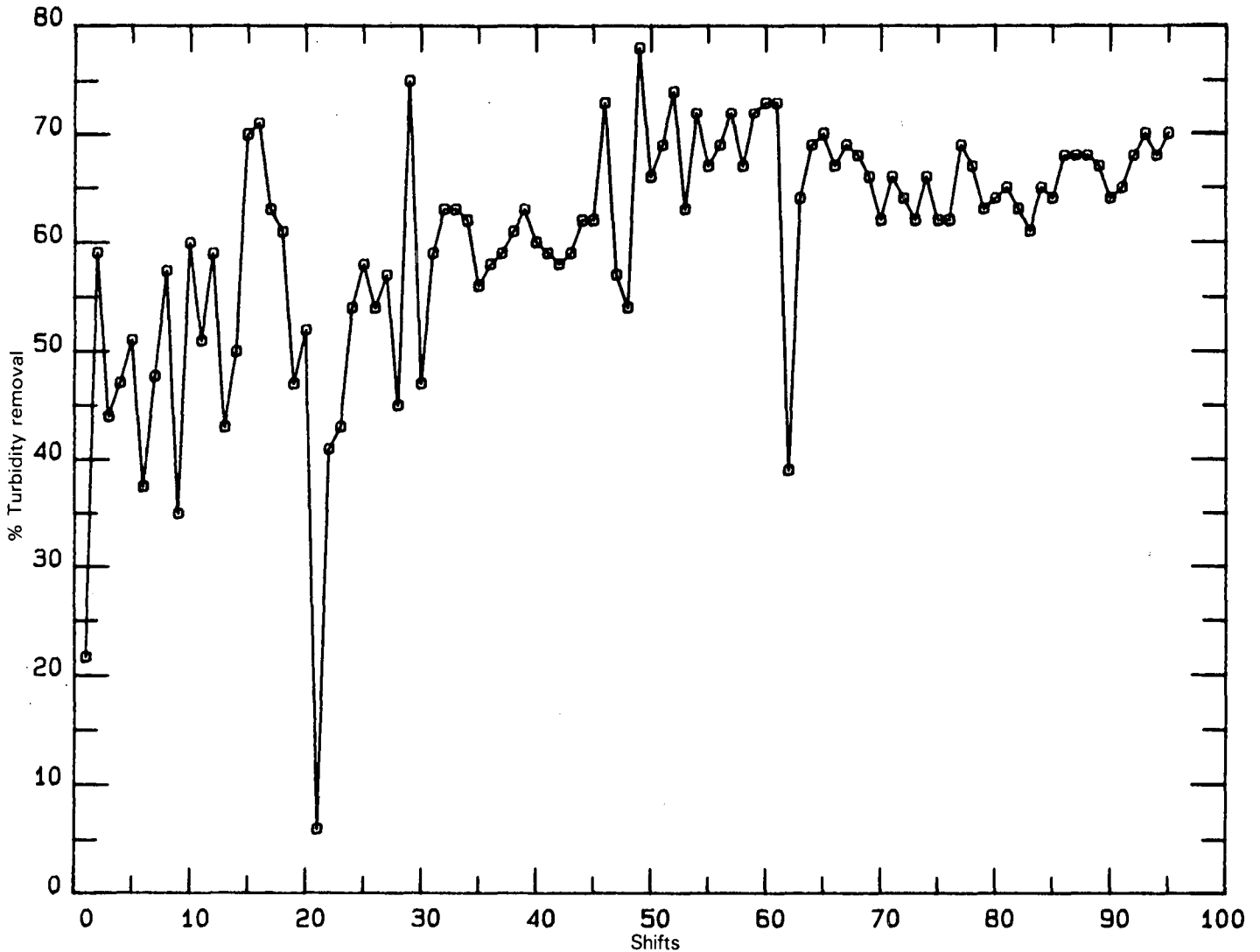

FIGURE 11 Turbidity removal measured in the Felixton syrup clarifier, average temperature 58 °C, during a test period.

A new syrup clarifier is being installed and should be in operation at the start of the 1987/88 season in Triangle in Zimbabwe. A sketch of the clarifier is shown in Figure 13.

### Conclusion

Flotation clarification has shown itself to be a cheap and effective form of improving raw sugar quality. This is particularly so since it is unnecessary to use phosphoric acid and lime in the process. Capital cost of the plant is low and operating costs consist only of the need to dose poly-electrolyte.

The syrup clarifier also results in lower massecuite viscosities. This benefits sugar boiling, but the extent of the benefits realised has not been established.

It is anticipated that syrup clarification will become more widespread in the future, particularly as the accent on sugar quality becomes more pronounced.

### Acknowledgements

The development of syrup clarification in Tongaat-Hulett Sugar has been a team project, and many individuals have contributed. What has been achieved is due to the input of all these people.

### REFERENCES

- Langenegger, O (1979). "Preliminary phase separation - flotation". *University of Pretoria Symposium on Water Purification Plant*, p 99.
- Matic, M (1969). Aspects of flotation clarification of mixed juice. *Proc S Afr Sug Technol Assoc* 43, 199-205.
- Blunt, R (1979). Written communication from Noodsberg Sugar Company.
- Desvaux de Marigny, JC (1982). Written communication from Belle Vue, Mauritius.
- Bennett, TT (1980). Complete syrup clarification at Davies Hamakua Sugar Company Haina factory. *Rep Hawaiian Sugar Technol* 39, 113-116.
- Saranin AP (1972). Technology of phosflotation of sugar melt. *Sug Technol Rev* 2, 1-72.

### APPENDIX 1

#### Method for measuring the turbidity of syrup

- Prepare a solution ca. 10 brix as per Laboratory manual for South African sugar factories.
- Prepare a slurry of 4 g Kieselguhr in a little of the solution to be filtered, and use this to form a pad on a Whatman No 5 filter paper (5,5 cm Ø) in a Buchner flask. Discard runnings.
- Filter a part of the solution under vacuum, discarding the first cloudy runnings.
- Measure the absorbance of the unfiltered solution at 720 nm on an LKB spectrophotometer against the filtered solution. The turbidity is the difference between these two readings.
- Measure the brix of the filtered solution.
- Correct the measured turbidity to 10 brix as follows:  

$$\text{Turbidity} = \frac{\text{Turbidity at measured brix} \times 10}{\text{measured brix}}$$

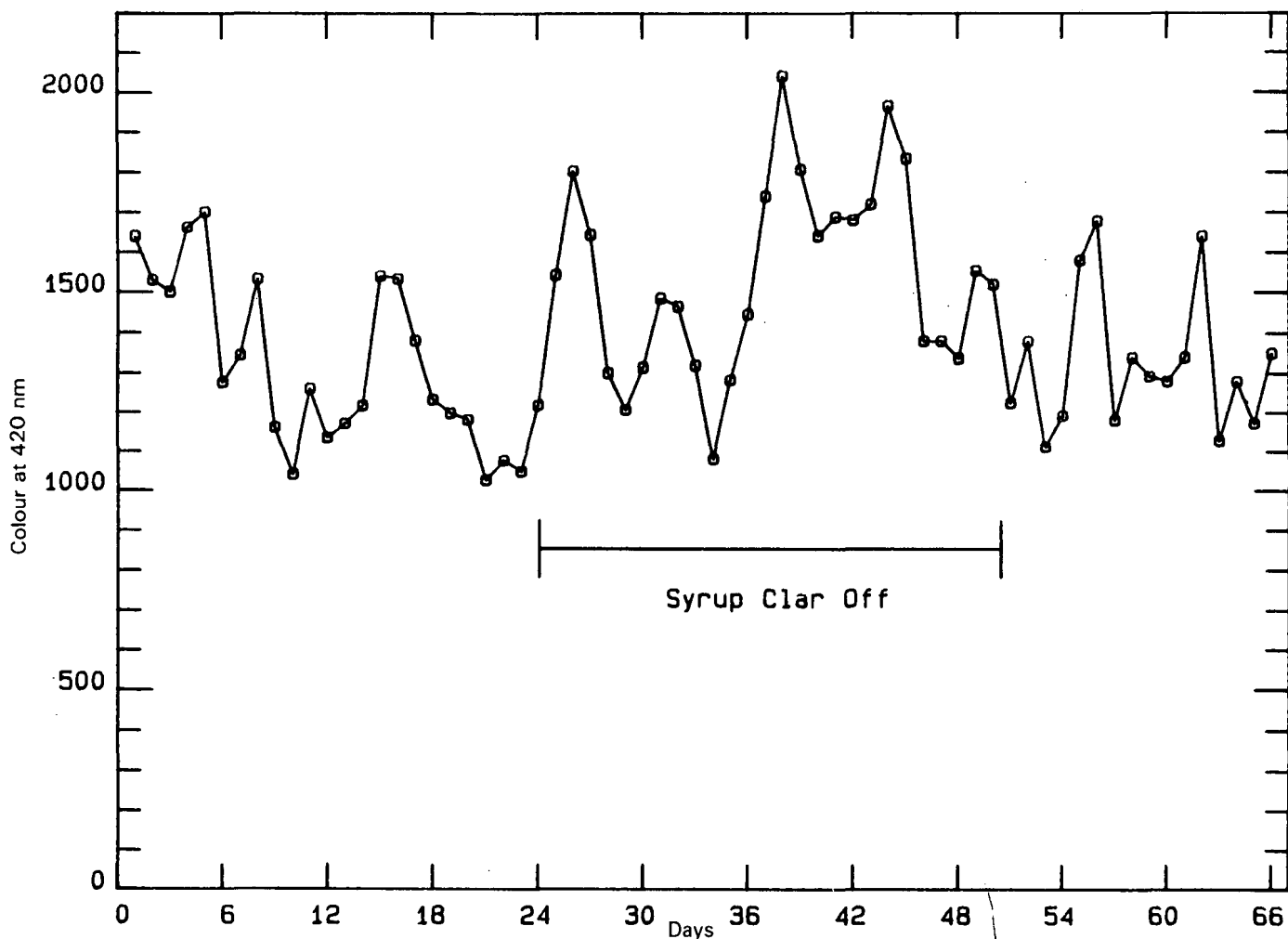

FIGURE 12 Colour of Felixton sugar delivered to the Refinery including a period when the syrup clarifier was taken off.

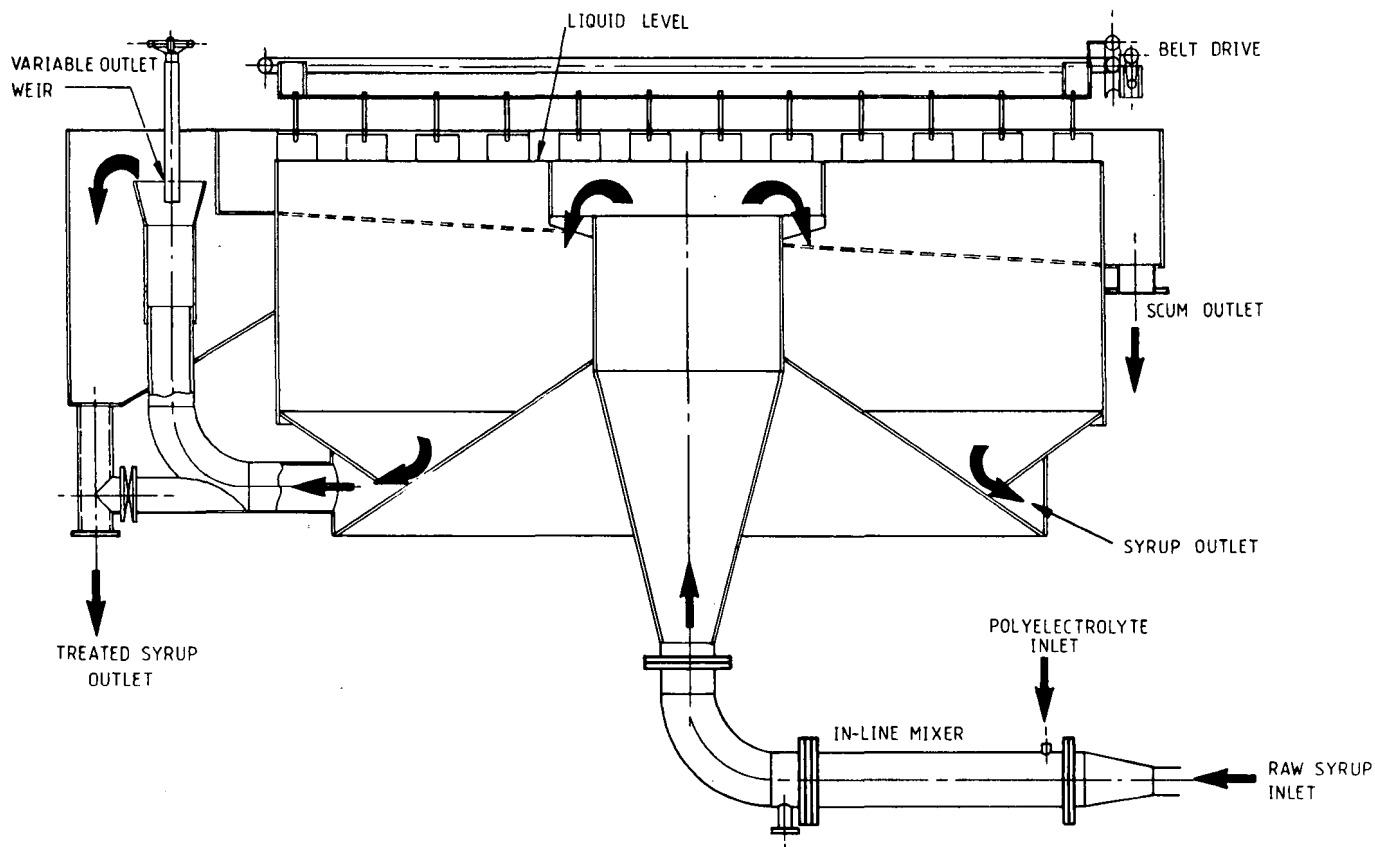

FIGURE 13 Sketch of the syrup clarifier installed at Triangle, Zimbabwe.