

# LIGHTNING, A HAZARD TO BE CONSIDERED

By F. CALBOUTIN

*Sugar Industry Central Board Cane Testing Service*

## Abstract

The upgrading of weighbridges from mechanical to electronic operation has highlighted the lack of lightning protection measures being taken by industry. Expensive sophisticated equipment is at risk in all parts of the factory. Power and data cable interconnections provide access for destructive transients which may be induced by lightning or other sources. The paper deals with the formation of a lightning storm and its effects on living and material objects. Damage to weighbridge and computer equipment is discussed, as well as protective measures taken by the Sugar Industry Central Board.

## Introduction

Since the early days of sugar factories there has been a need for a weighing system to provide information of tonnages of cane crushed and sugar produced. In the past the industry used a weighbridge system which consisted of an arrangement of levers operating a dial shaped scale with an electro-mechanical printer. While this system was fairly reliable it was maintenance intensive and did not provide an output enabling it to be linked to a computer. The conversion of old weighbridges to incorporate a single load cell has reduced maintenance and provides a digital signal output. The latest installations, using six load cells, have virtually eliminated maintenance. The load cell weighbridge is robust and reliable, but the adoption of sophisticated electronic equipment for use in sugar mills has led to the need for an understanding of the dangers presented by the natural hazard of lightning.

## The Evolution of a Thundercell

In the tropics thunderclouds are formed by heat or convective storms. These storms originate when hot air rises from the land, forced up by cool air from the ocean. The hot air cools as it rises, the water vapour condenses and begins to fall as rain drops.

Most of the drops are repeatedly carried up until they reach freezing height, where they turn into ice crystals. The air turbulence caused by this process results in a separation of electric charges, where the upper ice crystals are negatively charged and the lower water droplets are the negative ion carriers. The dipole effect creates intra-cloud and cloud to cloud flashes. About one third of thunder clouds are not true dipoles, but have another component which is important for cloud to ground discharges, that is a small region of positive charge near the lower leading edge of the cloud.

The earth can be considered as a large electrical conductor which carries a slight negative charge in normal weather. However, when a thundercell forms, the area of earth below it soon loses its negative polarity and takes on a growing positive charge. When this happens the electric field is reversed between the earth and cloud and the potential between the two charge centres soars, reaching values of 10 000 to 20 000 volts/metre or more. When the intensity of the electric field at the tip of a vertical object reaches a certain level, positive ions from the earth stream upward toward the negative thundercloud. The electrical field intensity con-

tinues to increase and the situation is ready for a lightning flash.

A flash begins with a breakdown of the air inside the cloud across the gap between the small positive charge and the large negative charge above it. This dislodges electrons which in turn overrun the small positive region in the lower leading edge, thus neutralizing it. The negatively charged step leader then continues downward to the attractive positive charge of the earth. The downward path of this pre-discharge stroke is in discrete steps of about 50 metres.

The step leader stroke ionizes the air channel as it moves down at a rate of 1600 m/sec. When it reaches about one step distance above effective ground an upward positive charge rises to meet it thus completing an ionized path. Immediately a massive, intensely luminous, return stroke rises up this path. As the return stroke moves up, heavy currents flow from the cloud along the entire length of the channel, thus dissipating the excessive negative atmospheric charge to earth. Having begun as a small cumulus cloud of rising, moist, warm air, a storm can quickly grow into a cumulonimbus thundercloud reaching a height of 10 km, and spreading over a distance of 35 km or more.

Most thunderstorms and lightning destruction occur between noon and midnight, when an estimated 3 billion lightning bolts strike the earth per year, the majority of strikes occurring in tropical regions.

## The effects of lightning

"The more civilized the world becomes, the larger and more costly lightning's negative role becomes, for it could hardly have been better designed to serve as a foe to high technology."<sup>1</sup>

Lightning is made up of cold and hot strokes with a ratio of approximately 1:3. Both strokes reach temperatures of 16 000 to 28 000°C. The difference between them is that the duration of a cold bolt is milliseconds and has a fast rise time, and it is this rapid change in state that causes most damage to electronic equipment. A hot bolt lasts for tenths of a second causing more physical and fire damage.

Lightning targets vary greatly in vulnerability. The ability of a lightning flash to inflict damage depends on the particular properties of the target coupled with the characteristics of the flash (eg. a steel structure or mechanical equipment is less susceptible to damage than a wooden structure or electronic instruments).

*Lightning exerts three major stresses on an object being struck*

*Thermal.* The heat generated by the flash causes the surrounding air to expand at a rapid rate. This instant expansion causes a pressure wave which produces a crack if close by, or thunder if at a distance. Such a pressure wave can lift tiles or even explode unprotected chimney stacks. The concrete foundations of a steel structure may show signs of flaking (spalling) or even crack due to the heat build up as the current forces its way to earth.

*Mechanical.* The mechanical effect of lightning is the physical force applied to a conductor as very large currents flow through it. The force tries to straighten out the conductor and may loosen rods or cables that are not securely fastened.

*Electrical.* Electrical stress can be induced by a side flash. This is when an arc is formed between the surge and a separate nearby body. The flash-over occurs because the body is separated from, and develops a polarity opposite to, that of the surge. Another electrical stress factor is induced voltage. This can be in the form of high amplitude pulses forcing their way into the equipment via power or data lines.

*Stresses on Buildings*

On an unprotected building the most vulnerable areas for lightning strikes are:

- The roof or projections
- Radio or television aerials
- Overhead power or phone lines
- Adjacent trees.

Buildings do however provide a protection zone which is mainly determined by height. Figure 1 shows the area attractive to lightning issued by a small building<sup>2</sup> (eg. a weigh-bridge office). The 30 metre radius from the corner of the building is equivalent to the length of a step leader which is attracted to the elevated ground level. A 15 metre high

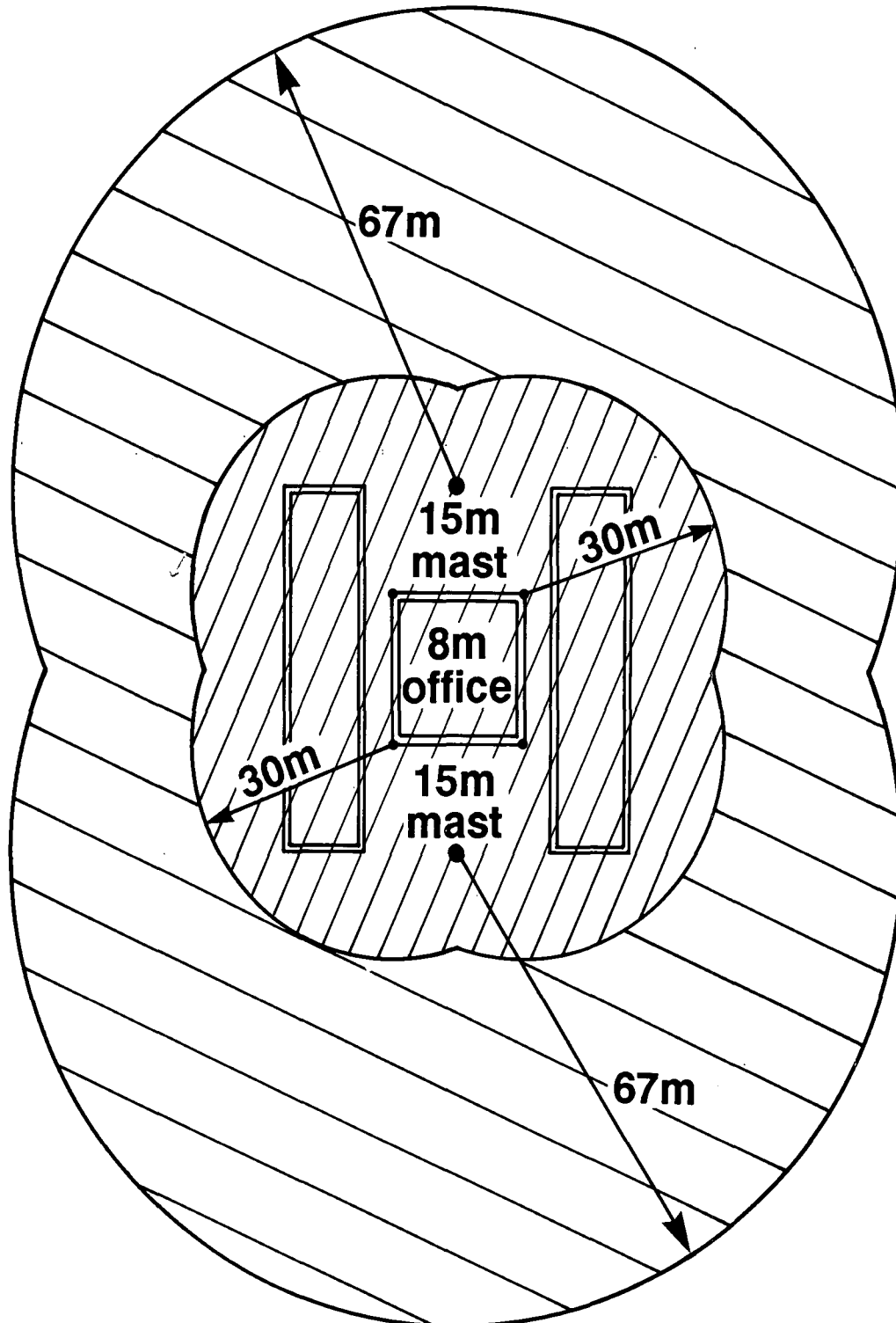

FIGURE 1 shows the area protected by a low building or mast.

mast with grounded air terminals will attract lightning over a distance of 67 metres. While it may appear that the higher the mast the greater the protection zone, it must be realised that the likelihood of being struck increases by 4:1, causing heavy currents to be dumped in the ground area near the weighbridge. If the grounding is good and everything is tied to the outer guard ring surrounding the weighbridge then there should be no problems. However, consideration of the area to be protected should determine the height of any installed masts.

*Effects of lightning damage to weighbridges and computer equipment*

The implementation of Autolab at Sugar Mills throughout the industry has brought about a small technological revolution in its use of computers and associated electronic equipment. One area of significant change has been the conversion of weighbridges from a mechanical to an electronic weighing system. This allows for greater throughput, a reduction in staff at most mills and the ability to link into a computer system.

While computers and electronics may seem to be the answer to most convenience and efficiency problems they do have a major enemy, namely electrical surges through the mains supply or via data lines. The seriousness of the damage is directly related to the time taken to restore normal operation, and to the cost involved in repairing damaged equipment. From 1982 to 1988 the following sugar mills experienced one (or more) strikes where serious damage occurred: Malelane, Amatikulu, Darnall, Gledhow, Maidstone, Noodsberg, Union Co-op and Illovo. Sugar Industry Central Board (SICB) was able to repair or replace their equipment in these weighbridges normally within a few hours. However, delays in the repair of scale equipment sometimes took a while longer (in one instance 72 hours) with a resulting stress on those responsible for the operation of the weighbridge and the continuity of cane supply. Moreover as the majority of mills are within relatively close proximity to one another, it is quite possible that more than one mill may be adversely affected by the same storm, causing considerable strain on the resources of SICB and the scale companies.

Not all lightning surges have the same destructive power. Most of those that do occur on the data lines are absorbed by protection circuits.

The effectiveness of these circuits is evident by the decrease in damage to computers and related equipment. The frequency with which the lightning converter/protection boxes are returned for repair due to lightning damage indicates the hostility of the environment.

Table 1 shows the occurrence of lightning ground flashes in the sugar belt, measured in strikes per square kilometre per year (figures rounded off) recorded from 1975 to 1986.<sup>3</sup>

While the above figures may not seem high it must be remembered that some mills cover relatively large areas, eg. Felixton 0,6, Amatikulu 0,47 and Darnall 0,35 km<sup>2</sup> added to which, the tall structures of factories attract a high percentage of those strikes.

*Lightning protection measures relating to the sugar industry*

**Buildings.** After the lightning damage caused at three sugar mills in 1982, it was decided that an attempt had to be made to provide some protection. Discussions took place with the S.A. Scale Company (SASCO), where it was decided that SASCO would fit a lightning protection kit to each weighbridge, while SICB would initiate the installation of earth mats to provide a ground connection for the weighbridges and a lightning mast. The SASCO kit consisted of nylon

bushes to isolate the loadcell from the platform and associated levers, and copper earth straps to connect all the metal parts of the weighbridge together. This was then connected to the earth mat. The earth mat was arranged in the form of a rectangle using 12 ground rods, each 1,5 metres long spaced 1,5 metres apart in 3 rows of 4 rods each. These rods are interconnected with 10 mm diameter copper cable, which was then to be connected to a lightning mast provided by the mill. Unfortunately not all mills complied with the request to provide a mast. These specifications were as recommended by the C.S.I.R at that time.

**Table 1**  
Occurrence of lightning in the sugar belt

Place	No. of strikes
Nelspruit	3
Komatipoort	3
Piet Retief	12
Pongola	7
Hluhluwe	6
Richards Bay	6
Empangeni	5
Eshowe	6
Mandini	4
Stanger	4
Greytown	6
Pietermaritzburg	7
Durban	5
Scottburgh	3
Margate	2

A number of mills have recently taken advantage of the latest technology by commissioning specialised lightning protection companies to install more extensive systems.

**Equipment.** The initial steps taken by SICB were to protect the power and data lines to the computer. This was achieved by installing a conditioned supply in the form of an Uninterruptible Power Supply (UPS). This system ensures clean and stable power which is fed by, but isolated from, the mill supply.

Equipment not on the UPS supply is either supplied via a constant voltage transformer as in most weighbridges, and/or has transient suppression power plugs fitted (cane tracker cabins). Some mills have installed their own UPS system in the weighbridge.

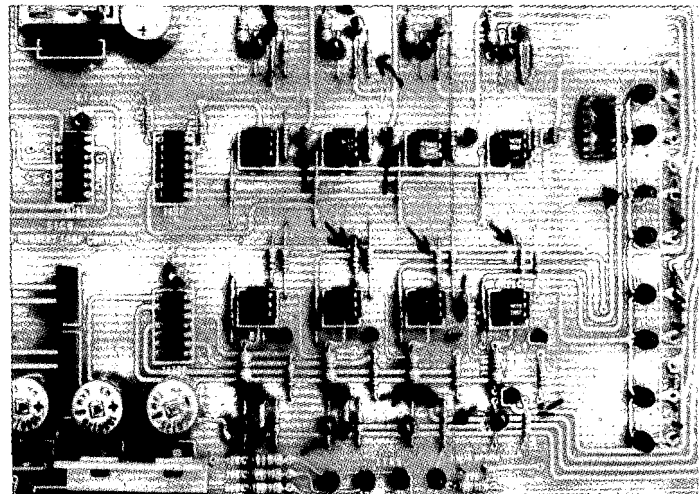

**FIGURE 2** Lightning damage to an original converter/protection board

The protection of data lines is more difficult, and the initial idea was simply to isolate the computer input from the weighbridge and tracker station data cables using an Opto-coupler device. After the problems of December 1982, when Maidstone and Amatikulu were severely damaged by lightning, it was decided that the system required revision (see Fig 2).

The original basic circuit was replaced by one containing opto-coupling along with three stage surge suppression in the form of high capacity metal oxide varistors, series resistors and fast acting transorbs (see Fig. 3).

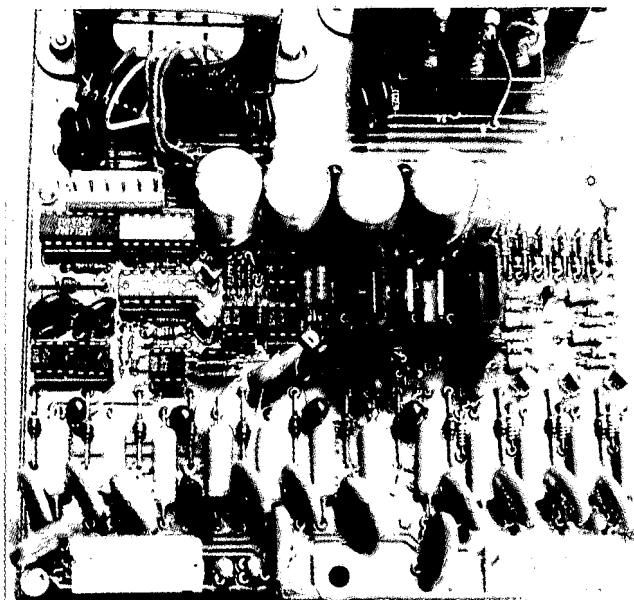

FIGURE 3 Lightning damage to the upgraded converter/protection board.

These current loop boxes provide a conversion from RS232 to 20 mA current loop signals as well as providing a degree of lightning protection. They were designed and manufactured by the SICB. To-date the upgraded version has proved to be very successful as there has been no severe damage to equipment at either end of the data lines.

Another problem occurs when lightning strikes on or near the weighbridge platform. This causes surge currents and induced voltages to flow through the loadcell, digitiser and all equipment attached to them, with resulting damage.

Unfortunately the link between most of the digitisers and instrumentation is in parallel form using 21 wires. At Pongola and Felixton the scale systems were installed by a different manufacturer to those operating in the majority of factories and their digitiser output is a serial two wire system. This has enabled Central Board to develop a fibre optic link to interface between the digitiser and downstream equipment. Any lightning damage is now limited to the loadcell digitiser and optical driver, of which the latter is small, inexpensive and easy to replace. This fibre optic link has the added advantage that it can be by-passed in the event of circuit failure. A prototype of this circuit (see Fig. 4) was installed and successfully tested at Felixton sugar mill for the final two weeks of the 1988/89 season.

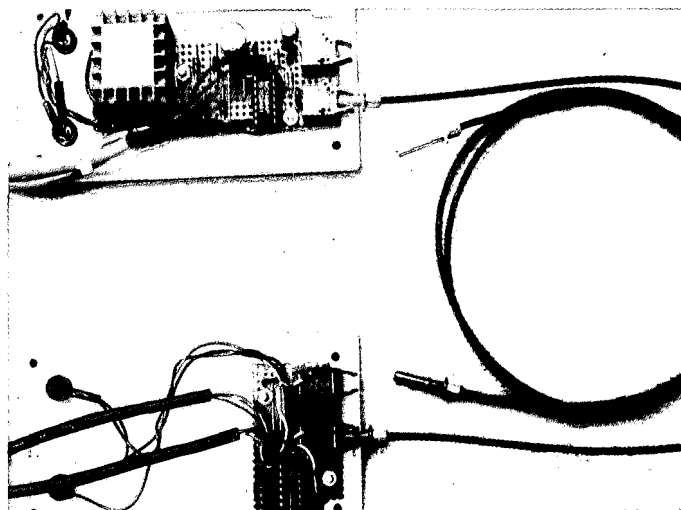

FIGURE 4 Prototype fibre optic link

### Conclusion

The sugar industry is making greater use of high technology in the form of instruments and computers, and in doing so has exposed an area highly susceptible to damage by electrical disturbances. These disturbances may be from lightning strikes or other power sources. If adequate precautions are not taken there could be serious damage to equipment resulting in expensive repairs, lost production and high insurance premiums. While lightning damage cannot be eliminated, its effects may be greatly reduced by employing relatively inexpensive preventative measures.

### Glossary of terms

Opto-Coupler = A integrated circuit that transfers information using optical means.

Varistors = Metal oxide varistors, which are voltage dependent resistors.

Transorbs = Transient voltage suppressors, which are similar to, but an improved version of, a very fast zener diode.

### Acknowledgements

The author wishes to thank Electronic Designs for permission to use material presented in a seminar on lightning protection given by members of the Lightning Protection Institute of the U.S.A. at the Rand Afrikaans University, Johannesburg 1988, and the Sugar Industry Central Board for permission to publish this paper.

### REFERENCES

1. *School of Lightning Protection Technology Inc.* (1983) Unit 3 pl. Woodstock, Illinois.
2. *Pontins R.S.A.*, Randburg, Transvaal, from seminar handbook. (1987).
3. Geldenhuys, H (1986) *Lightning Recording Scheme (1975-1986)* Division of Energy and Technology C.S.I.R., Pretoria.