

SELECTION OF VARIETIES SUITABLE FOR EARLY HARVEST IN MAURITIUS

By R. DOMAINGUE, L. MAMET and H. MUNGUR

Mauritius Sugar Industry Research Institute, Réduit, Mauritius

Abstract

In plantations there is a lack of varieties which ripen early in the season; hence nine series of trials were implemented in four different environments to assess the efficiency of selecting for early ripening varieties at stages 3 and 4 (one and two lines respectively). In each trial, varieties were duplicated for early season (June) and mid-season (September) harvests. In all trials selection rates were higher for early season harvest. All varieties selected for mid-season harvest were also selected early. Thus a large percentage of varieties suitable for early season harvest are lost if assessment is performed at mid-season. Many of these had high brix and high cane weight. No varieties suitable for harvesting at mid-season were lost if selection was performed early in the season. In order to select varieties with different maturity characteristics from stage 3 onwards, it is now necessary to sample varieties earlier in the harvesting season.

Introduction

Selection for early season ripening sugarcane varieties is a priority in many countries. Early varieties are needed to improve the sugar recovery at the beginning of the harvesting season, e.g. in Mauritius, Louisiana and Australia (unpublished data; Lingerfelt *et al.*,¹¹ Hogarth,⁸) and to extend the milling period, e.g. in India (Rao¹²). Short duration canes are often termed early maturers (Buzacott,⁴ Bond,² Rao,¹² Breaux,³) and are required for frost avoidance in subtropical regions (Herbert and Rice⁷), to allow early land clearance for the cultivation of secondary crops (Ethirajan⁶) and may enable the production of three crops in two years (Rao¹²).

There is a paucity of early season ripening cultivars; consequently there is widespread interest in artificial ripeners and in various field practices such as topping, water regulation and fertilizer programming which could induce the crop to ripen earlier (Alexander¹). In Mauritius, pol % cane is generally low early in the season (Julien and Delaveau⁹) despite the use of ripeners and appropriate water and fertilizer management (unpublished data). Peak sucrose content is usually around the month of October and yet the harvesting season is spread over the period July to December. Early ripening varieties are therefore essential to improve returns at the beginning of the season.

Early sugarcane varieties are defined in various ways in different countries. For physiologists "earliness" is the ability of certain varieties to start the ripening phase earlier while plant breeders and commercial growers consider it to be the ability of certain genotypes to accumulate an "acceptable" amount of sucrose after a relatively short growing period (Cuenya and Mariotti³). This short growing period is itself a function of the normal growing period. In Mauritius earliness is considered as the ability to accumulate a profitable amount of sucrose at the beginning of the harvest season (around the month of July) (unpublished data). Early ripening tends to be a feature associated with varieties with a high inherent sucrose content, but Bond² argues that early maturing (early ripening) characteristics may be present in va-

rieties of average sucrose content. According to Bond there are few, if any varieties that can be defined as early maturing, in that the sucrose content of the variety reaches a maximum early in the season and then declines. Rather, the so-called early varieties are those that have relatively high sucrose content early in the season, and the level continues to increase.

Earliness has proved to be a difficult character to attain in the breeding and selection programme in Mauritius. The current selection programme can be divided into two distinct phases, the preliminary selection and the final variety testing phases (Fig 1). The preliminary phase consists of four stages. At stage 1 (seedlings) 80 000 progenies are evaluated visually every year. Stage 2 is a single stool stage where 25 000 progenies are evaluated on the basis of field refractometric Brix, vigour and cane number. Stage 3 is a one line \times 5 m stage with 2 500 genotypes which are evaluated till the first ratoon stage across three environments. Varieties are normally sampled in September for plant cane and in July for the first ratoon. Stage 4 is the first replicated trial

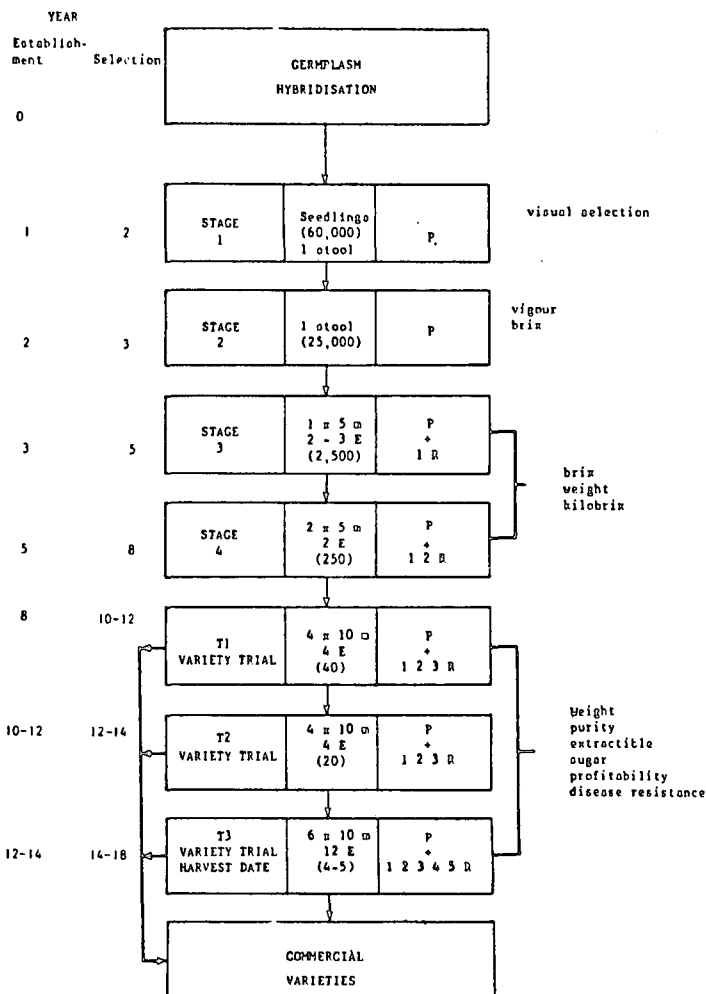

FIGURE 1 The selection programme at the Mauritius Sugar Industry Research Institute

of two lines × 5 m. About 250 varieties are evaluated till the second ratoon stage across the environments, in September for plant cane and first ratoon, and in July for the second ratoon. Selection for stages 3 and 4 is carried out on cumulative field refractometric brix, cane mass and kiloBrix (cane weight × Brix).

The final selection phase consists of three series of trials. The T1 trial, harvested at mid-season, includes 40 varieties evaluated in four main agroclimatic zones till the third ratoon crop. The T2 trial, harvested early in the season, includes 25 varieties evaluated in four complementary soil types for the same number of ratoons. Six varieties are tested every other year in the T3 maturity trials in twelve environments and at three harvest dates. Selection for all trials is based on Industrial Recoverable Sucrose Content (IRSC), cane yield, sugar yield and fibre content.

It was postulated that the current selection procedures and criteria negated the breeders' efforts to produce early ripeners by eliminating these genotypes in the preliminary stages. In order to test this hypothesis a number of stage 3 and stage 4 trials were duplicated for selection at early harvest (June) and mid-season harvest (September).

Materials and Methods

The present study was undertaken at stages 3 and 4 of the preliminary phase of selection.

1. Stage 3 trials

Three series of stage 3 trials were planted in three environments: Union Park in the super-humid zone, Britannia in the humid zone and Pamplemousses in the sub-humid zone. Each series was made up of two similar trials, one for early harvest (mid-June to mid-July) and the other for mid-season harvest (September). The trials were planted according to stage 3 layout, i.e. each variety under test occupied one line of 5 m. One standard variety (M 555/60) was replicated in rows and columns as previously described by Lalouette¹⁰.

The numbers of varieties planted in each series of trials were 103, 136 and 62 in the super-humid, humid and sub-humid zones respectively. Varieties were chosen at random from stage 2 of the selection programme. The trials were harvested in plant cane and first ratoon and the characters measured at harvest were cane mass and brix, while kiloBrix (cane mass in kilograms × Brix) was computed.

Selection for brix and kiloBrix was performed against the standard variety at $P \geq 0,75$ according to the analysis described by Lalouette¹⁰.

The total selections at each harvest date as well as the relative selection of varieties between the two dates were assessed.

2. Stage 4 trials

Five series of stage 4 trials were planted in three environments as follows: two in the super-humid environment (one at Belle Rive and the other at Union Park), two in the humid (Britannia) and one in the sub-humid (Pamplemousses). Each series was made up of two similar trials. The design adopted for each trial was an incomplete square lattice and there were two replicates. Each plot was made up of two rows of 5 m and planted with varieties selected from stage 3 of the selection programme.

In the super-humid environment 17 varieties were planted at Belle Rive, and 20 at Union Park; 34 were planted in the

humid zone and 20 in the sub-humid zone. Several standard varieties of varying ripening characteristics were used in these trials.

The trials were harvested in plant cane, first and second ratoons and selection depended on the cumulative results of these three crops. The same characteristics as in stage 3 trials were assessed and selection depended on the average of all standards in the trials. Selections were assessed as for stage 3 trials.

Results

1. Varieties selected at two harvest dates

In all the trials planted and evaluated at stages 3 and 4 in various localities, there were more varieties selected early (July) than at mid-season harvest (September) (Tables 1 and 2). Out of 103 varieties evaluated in the super-humid environment, 39,8% were selected early and 17,5% later in the season on the cumulative results of plant cane and first ratoon. Similarly out of the 136 varieties tested in the humid environment, 27,9% were selected early but only 5,9% at mid-season harvest. Selection rates were 41,9% early in the season in the sub-humid zone but very low (1,6%) later.

Table 1

Percentage of varieties selected for kilobrix ($P \geq 0,75$) in plant cane, first ratoon and on cumulative results at early (E) and middle (M) harvest, in three different climatic zones

(Stage 3)

Crop Cycle	Harvest Date	Climatic zones		
		Super-humid	Humid	Sub-humid
Plant cane	E	68,9	46,3	41,9
	M	46,6	24,3	12,9
First ratoon	E	14,6	18,4	32,2
	M	2,9	2,9	6,5
Cumulative	E	39,8	27,9	41,9
	M	17,5	5,9	1,6
Total evaluated	E	103	136	62
	M			

Table 2

Number of varieties selected at Stage 4 for kilobrix ($P \geq 0,75$) in different crops, at two harvest dates, and in two climatic zones

Crop cycle	Harvest date	Super-humid*	Humid*
Plant cane	Early	12	5
	Middle	5	2
First ratoon	Early	9	6
	Middle	6	4
Second ratoon	Early	10	8
	Middle	4	2
Cumulative	Early	10	4
	Middle	2	3
Total evaluated		37	34

* Total of two trials

In stage 4 trials, selection rates were also higher early in the season, especially in the super-humid zone, although fewer varieties were evaluated.

The same tendency was observed in both crop cycles although more varieties were selected at both dates in the plant cane crop than in the first ratoon crop (Table 1).

2. Early varieties lost

The data were analysed so as to determine the relative number of varieties which could perform well early in the season but which were lost if selection was performed in September (Table 3). The percentage of potentially good varieties suitable for early harvest and lost in stage 3 trials amounted to 29,1, 22,1, and 40,3 in the super-humid, humid and sub-humid environments respectively. With the exception of one testing site in the super-humid zone, a smaller percentage of early varieties are lost when selection is performed at mid-season at stage 4.

Table 3

Percentage of potential early varieties lost from populations evaluated at mid-season harvest at stages 3 and 4 in different climatic zones

1. Stage 3

Crop cycle	Climatic zones		
	Super-humid	Humid	Sub-humid
Plant cane	31,1	26,5	32,3
First ratoon	13,6	15,4	30,6
Cumulative	29,1	22,1	40,3

2. Stage 4

Crop cycle	Climatic zones		
	Super-humid		Humid
	Union Park	Belle Rive	
Plant cane	5,0	45,0	8,8
First ratoon	15,0	25,0	5,9
Second ratoon	5,0	35,0	20,6
Cumulative	15,0	40,0	5,9

3. Characteristics of early varieties

Among the group of varieties selected early in the season only in Stage 3 trials, more than 40% had high Brix ($P \geq 0,75$) in July, thus displaying characteristics of early varieties (Table 4). This tendency was more pronounced in the super-humid zone, especially in the first ratoon crop.

The accumulation of Brix, expressed as a percentage increase from July to September in varieties selected early, is presented in Fig 2. There was a tendency for poorer varieties to accumulate more Brix from early to middle harvest, as compared to richer ones, particularly in the sub-humid and super-humid zones. There were also examples of richer varieties with a larger percentage increase in Brix and poorer ones with a lower increase in the humid environment.

Table 4

Percentage of varieties with high brix ($P \geq 0,75$) at early harvest among those selected for kilobrix at this date only (stage 3)

Environment	Plant cane	First ratoon	Cumulative
Super-humid	53,1	85,7	63,3
Humid	63,9	33,3	60,0
Sub-humid	40,0	66,7	44,0

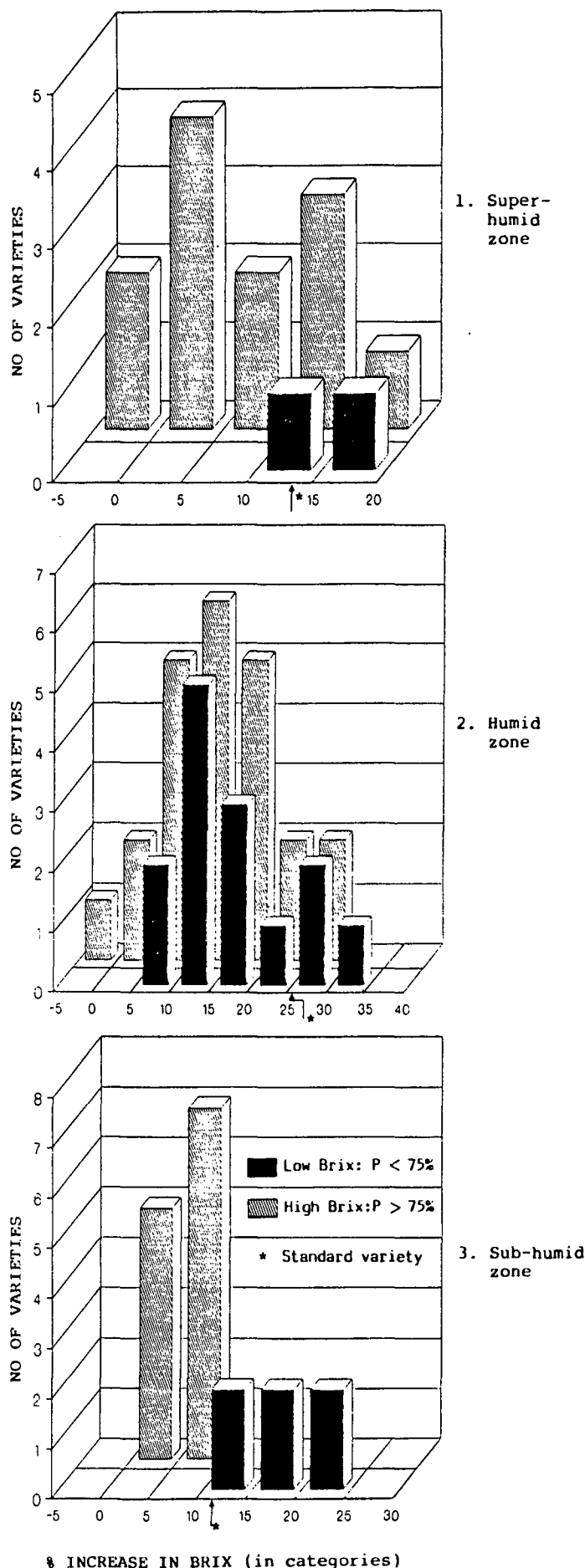

FIGURE 2 Percent increase in Brix from July to September of rich ($P > 75\%$) and poorer ($P < 75\%$) varieties selected at early harvest only in different environments

Owing to fewer selections at stage 4 it proved more difficult to perform this assessment, but there are some indications that up to half the number of varieties selected at early harvest only could possess characteristics of early varieties, especially in the super-humid environment.

Discussion

The data collected from the trials indicate beyond doubt that more varieties are selected when selection is performed in July (early), irrespective of the group of varieties used and the experimental sites. It should be noted however that this percentage could have been accentuated at stage 3 because of the lower Brix of the late maturing standard variety, which is normally used for selection.

Early varieties are generally those which display high Brix early in the harvesting season, but there was a fair percentage of varieties selected in July which had lower Brix. Bond² also reported that early maturity tends to be a feature of varieties with high sucrose, but that early maturing characteristics may be found in varieties of average sucrose content. Our data also suggest that amongst the rich varieties ($P \geq 0,75$) selected in July at stage 3, certain genotypes were typically the so-called early ripeners in that their early high sucrose did not increase substantially from early to late harvest. On the other hand, many of the rich and early genotypes continued to accumulate sucrose over the harvesting period, but were not selected for kiloBrix at mid-season harvest, because of their low cane yields then.

Although varieties which have peak Brix values early in the season are reported to be rare, it appears that appropriate selection procedures can identify such varieties and that they could also enable growers to start harvest with profitable and rich varieties.

By performing selection early in the season, the number of varieties retained for further evaluation is substantially increased, while the chances of losing early varieties are reduced. It is therefore proposed to modify the current selec-

tion procedures by evaluating varieties in July at these two stages. However, as a means of avoiding a large increase in the number of varieties being promoted for further evaluation, it would be preferable if only those with high Brix coupled with acceptable cane yields be retained.

Acknowledgements

We are grateful to the staff of the Plant Breeding Division and the sugar estates concerned for their help and collaboration.

REFERENCES

1. Alexander, AG (1973). *Sugar cane physiology: a comprehensive study of the Saccharum source-to-sink system*. Elsevier. Amsterdam, London and New York.
2. Bond, RS (1982). Maturity differences between varieties in the selection programme. *Proc S Afr Sug Technol Ass* 56: 136-139.
3. Breaux, RD (1984). Breeding to enhance sucrose content of sugar cane varieties in Louisiana. *Field crops Res* 9, 59-67.
4. Buzacott, JH (1956). Breeding canes for high sugar. *Proc int Soc Sug Cane Technol* 9: 553-560.
5. Cuenya, MI and Mariotti, JA (1986). Selection of sugarcane for quality components and ripening ability. *Proc int Soc Sug Cane Technol Ass* 19: 429-439.
6. Ethirajan, AS (1973). Varietal suitability for different periods of crushing and for different regions. *Cane Growers Bull* 1 (4), 3-6.
7. Herbert, LP and Rice, ER (1972). Maturity studies of commercial sugarcane varieties in Florida. *Proc int Soc Sug Cane Technol Ass* 14: 137-144.
8. Hogarth, DM (1988). Research seeks early high C.C.S. cane varieties. *BSES. Bull*, 24, 7.
9. Julien, MHR and Delaveau, P (1977). The effects of time of harvest on the partitioning of dry matter in three sugar cane varieties grown in contrasting environments. *Proc int Soc Sug Cane Technol* 16:(2) 1755-1770.
10. Lalouette, JA (1968). Breeding of sugarcane varieties in Mauritius. *Proc int Soc Sug Cane Technol* 13: 1063-1067.
11. Lingerfelt, CW, Ellis, TO and Arceneaux, G (1965). Varietal relationships in available sugar content as affected by period of harvest. *Proc int Soc Sug Cane Technol* 12:474-478.
12. Rao, JT (1978). Methods in sugarcane breeding. *Proc Symp Trop Agric Res*, Trop Agric Series No 11, Japan.