

# REVIEW OF THE DEVELOPMENT AND PERFORMANCE OF AN ARTICULATED INFIELD HAULAGE UNIT ON A LARGE SUGARCANE ESTATE

By I. WORRALL<sup>1</sup> and E. MEYER<sup>2</sup>

<sup>1</sup> Tongaat-Hulett Sugar Mills and Estates (Pty) Ltd, Mount Edgecombe

<sup>2</sup> South African Sugar Association Experiment Station, Mount Edgecombe

## Abstract

It has been claimed that purpose-built tractor based mid-steer articulated haulage units have an infield manoeuvrability and traction advantage over conventional front-steer haulage combinations. In the 1988/89 season Cornubia Estate of Tongaat-Hulett Sugar Ltd, decided to purchase such a vehicle and assess its performance against standard haulage units operating under similar infield conditions. The results of these tests and modifications to the articulated tractor/trailer combination are described and discussed.

## Introduction

The Cornubia Estate harvests about 75 000 t of sugarcane annually. Some 90% of the crop is burned at harvest. The soils on the estate are derived from a wide range of parent materials, which include Red and Grey recent sands, dolerite and alluvium. The terrain is generally undulating with some very steep slopes and numerous wet valley bottoms. The entire crop is manually cut and stacked into four ton bundles. Before the 1987/88 season, the bundled cane was transported an average distance of 1,75 km using five single stack self-loading trailers coupled to conventional front steer tractors, to one of 10 transloading zones. A single tractor-mounted transloading crane tranships the cane into in-house hilo road haulage vehicles, which transported the cane to the Mount Edgecombe mill over a 12 h night delivery period.

Although the existing infield units generally performed well and coped with the estate's daily allocation in dry weather conditions, these units experienced difficulties in manoeuvring in confined spaces, and in wetter areas often became bogged down. The result was that, under such conditions, a large four wheel drive tractor had to be on standby to assist the infield haulage units.

The existing infield transport units were due for replacement at the end of the 1987/88 season. After discussion and investigation, it was discovered that a commercial company had designed a hitch for converting the standard two wheel drive agricultural tractor to an articulated tractor/trailer combination. It was felt that such an articulated twin stack combination could solve both the manoeuvrability and traction problems, and improve infield haulage productivity.

## Implementation

Although articulated infield haulage units have been used extensively in the timber industry for some time, their use in the sugar industry has been limited. During the latter part of the 1988/89 cane season, it was decided to convert a new standard Massey Ferguson 375 tractor, incorporate the commercially designed hitch, and couple this to a twin stack self-loading trailer. The performance of the articulated haulage unit would then be compared with a standard front wheel steer Massey Ferguson 375 tractor also coupled to a twin stack self-loading trailer. Details and design features of the two vehicles are as follows:

### Standard haulage unit

This consists of a high speed MF 375, 51 kW two wheel drive off the floor tractor, equipped with 18.4/15-30 rear tyres and a conventional trailer hitch. The twin stack self-loading trailer is equipped with walking beam axle. The trailer is fitted with 12.00-16 tyres and incorporates a conventional hydraulic 'S' cam braking system.

### Articulated haulage unit

This consists of a standard MF 375, 51 kW tractor equipped with 18.4/15-34 rear tyres. The front axle assembly was removed, and the integral hitch fitted to couple the tractor to

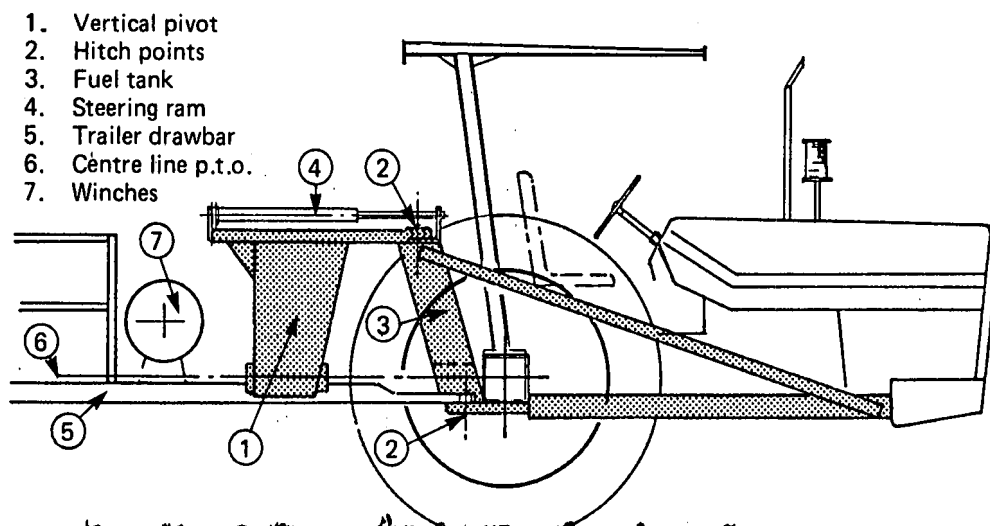

FIGURE 1 The integral hitch

a trailer similar to that described above. A simple diagram of the hitch is shown in Figure 1. The trailer is coupled to the hitch by two off-set ball couplings. The hitch is designed to allow lateral movement of the tractor in both directions for steerage and limited vertical movement.

The two haulage units were put into service on the estate during the latter part of the 1988/89 season. Although the operators had to become accustomed to the new vehicles, the two haulage units performed extremely well. The initial response by the operator of the articulated unit was very encouraging. He enjoyed the direct and positive steerage which enabled him to easily align and position the unit next to stacked cane bundles, and the improved ride of the unit on rough roads on both the outgoing loaded and empty return legs of the haulage cycle. The improved ride reduced the fatigue normally associated with this arduous task and, in the long term could well reduce operating costs. The articulated unit was less prone to becoming bogged down, because of its ability to 'walk out' of difficult field conditions.

Although the articulated unit has a larger turning circle than the standard unit, its overall performance on steeper terrain, especially when operating in trashed fields, was superior. Based on observations, it appears that the articulated unit's rear wheel tyre wear was less than that of the standard unit, despite the standard unit's rear tyres being filled with water. This reduced tyre wear can only be ascribed to reduced wheelslip as a result of higher rear axle loading.

A number of modifications had to be made to the articulated tractor combination during the initial phase. It was found that the MF 375 epicyclic housing was not robust enough. After cracking a number of housings (due to a combination of factors including increased total mass and additional stress placed on the tractor rear axle), heavy duty MF 390 epicyclics were fitted. To reduce steerage effort, larger diameter hydraulic steering rams also were fitted.

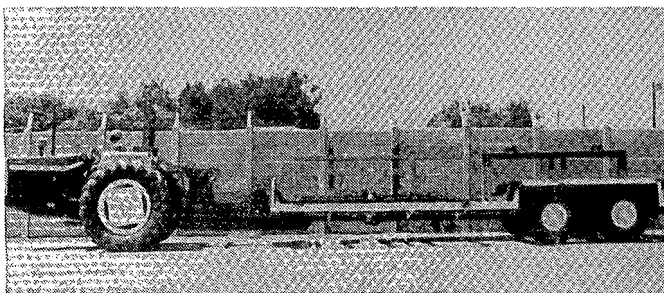

FIGURE 2 Articulated twin-stack haulage unit

### Comparative haulage test results and discussion

#### Simulated haulage test

During March 1989, a comparative evaluation of the standard MF 375 and the articulated tractor, both coupled to twin stack self-loading trailers, was conducted by the SASA Experiment Station Agricultural Engineering Department on the La Mercy farm. (Unpublished report). The tests were designed to represent an infield haulage situation. Factors affecting the performance of haulage units, notably condition of the road surface, climatic factors and topography, operator technique, tyre pressures and weight distribution were similar, so that the tests could be compared without favouring one unit over the other.

The tests were conducted on a 2,3 km circular route consisting of gravel hardened roads (60%), grassed access roads (35%) and weak sands infield (5%). The gradients varied between 0 and 10%. Two tests were performed for each tractor unit, the first with an empty trailer and the second with

10, 12 tons of ballast loaded uniformly over the length of the trailer beds. Steel blocks were used as ballast, and the loads and mass distribution were measured on the Tongaat-Hulett Maidstone mill weighbridge.

The circuit was traversed twice, in opposite directions, using the same tractor operator. Fuel consumption was measured by a Micro-Oval II fuel flow meter and recorded on an electronic data logger fitted to the tractors. A built-in clock recorded the time taken to complete the circuit. The number of revolutions of the tractor rear wheels over the route was measured by a transducer fixed to one drive wheel. Each revolution of the tractor rear wheel activated a magnetic switch six times, and these data were also fed into the data logger.

The information was retrieved from the data logger with a standard personal computer. Average fuel consumption, speed and wheel slip for the combined empty and laden cycles over the test route, as shown in Table 1, could then be computed. The various axle loadings for both the haulage units (when unladen and ballasted), are given in Table 2.

Table 1  
Simulated haulage test results

	Articulated MF 375 plus twin stack trailer	Standard MF 375 plus twin stack trailer
Fuel consumption (ℓ/h)	6,65	6,60
Specific fuel consumption (ℓ/tkm)	0,059	0,059
Haulage capacity (t/h)	12,17	12,15
Average speed (km/h)	11,07	11,05
Average wheelslip (%)	1,00	1,30

Table 2  
Comparative axle loadings

	Articulated MF 375 plus twin stack trailer	Standard MF 375 plus twin stack trailer
Empty trailer	-	1 240 kg
Tractor front axle	-	3 400 kg
Tractor rear axle	4 300 kg	1 700 kg
Trailer front axle	1 680 kg	1 720 kg
Trailer rear axle	1 680 kg	-
Laden trailer	-	1 000 kg
Tractor front axle	-	6 640 kg
Tractor rear axle	7 140 kg	5 280 kg
Trailer front axle	5 360 kg	5 260 kg
Trailer rear axle	5 280 kg	-

Results in Table 1 in terms of fuel consumption, specific fuel consumption, haulage capacity and average speed, indicate that the performance of both tractor haulage units were similar with marginal differences only between them. This was to be expected, as both units were equipped with the same type of engine and transmission. Soil moisture conditions during the test period were relatively dry, but it would be reasonable to assume that, had soil and road conditions been less favourable, the articulated haulage unit would have performed better than the standard haulage unit as far as rolling resistance and wheel slip were concerned.

The only appreciable differences in axle loading, as indicated in Table 2, were the higher loadings on the articulated tractor axle when the trailer was both empty and laden. It is interesting to note that 2,8 tons, or about 28% of the 10,12 ton payload, was transferred onto the drive axle of both the articulated and standard tractors.

**Table 3**  
Comparative performance between standard and articulated MF 375 haulage units

Tractor type	Cycle time - %							Performance data					
	Travel to field	Setting chains & cables	Winching bundles	Tightening chains	Infield travel	Travel to zone	Off-loading	Down time	Average cycle time-min	Average haul. dist km	Average travel speed-km/h	Average payload -tons	Tons delivered per hour
Standard	12,06	12,68	4,92	5,36	14,17	24,18	10,19	16,44	29,78	1,37	15,32	7,25	14,86
Articulated	18,68	16,57	4,96	7,13	12,11	23,93	9,91	6,71	26,85	1,43	15,05	6,92	15,56
Standard	18,72	22,77	4,33	6,37	5,54	11,23	17,62	13,42	31,92	1,70	21,25	8,35	15,75
Articulated	18,60	16,91	4,37	10,62	11,99	23,38	8,55	5,58	26,13	1,75	18,92	6,75	15,52

The fact that the articulated tractor rear axle loading was greater when the unit is empty, meant that this unit would be more manoeuvrable than the standard unit when entering steep fields and positioning itself next to the cane stacks. Furthermore, because of the greater mass on the driving wheels and because the unit had no steering axle, operator comfort was improved considerably on the empty return trip. The additional initial mass on the driving wheels also obviated the need to attach dead mass pieces to the drive axle to improve traction and manoeuvrability when empty. It is interesting to note that the articulated unit's total combined mass was 400 kg less than that of the standard unit.

*Time and motion studies*

Accumulative time studies were conducted by the SASA Experiment Station Agricultural Engineering Department during normal infield operations on Cornubia Estate. The studies were carried out over various haulage distances and terrain, when fields were both wet and dry. The various elements of the field operations were studied by recording the beginning and end of each element without returning the stopwatch to zero. The various element times were recorded on a field time study sheet, and this information was later entered into a HP41C programmable pocket calculator. The total number of times the element occurred, the average duration of each element and the percentage of each element's time, as a percentage of the total time, was therefore easily computed.

Average travel speeds could be calculated and if stack weights were recorded, the average capacity of the haulage units could be obtained.

The results of a limited number of time study observations to which similar payloads, haulage distances and operating conditions pertained are given in Table 3. From the data obtained in the time and motion studies, there appeared to be no difference between the two haulage vehicle types as far as haulage capacity was concerned. It should be emphasized that, during these observations, the articulated combination was always used to extract the cane bundles located in the worst situations.

*Operational observations*

Estate staff recorded the performances of both the standard and articulated infield haulage units under normal operating conditions on the estate over a considerable period. The performances of an articulated MF 390 twin stack self-loading trailer combination, as well as various other makes of standard haulage tractors coupled to similar trailers, were also noted.

The comparative performances of the standard and articulated MF 375 haulage units, each coupled to twin stack

self-loading trailers during specific periods in which they were operating under similar field conditions, are given in Table 4. The comparative performances of the standard and articulated MF 375, and an articulated MF 390 twin stack self-loading trailer combination for two separate observation periods, are shown in Table 5.

**Table 4**  
Comparison of specific fuel consumption for Observation Periods 1 and 2

Tractor type	Observation period 1		
	Standard MF 375 + twin stack trailer	Articulated MF 375 + twin stack trailer	Standard 60 kW tractor + twin stack trailer
Total tons transported	1 055	1 182	920
Total fuel consumed (ℓ)	366	351	365
Fuel eff. (ℓ/100 tons)	34,69	29,70	39,67
Observation period 2			
Total tons transported	816	753	818
Total fuel consumed (ℓ)	285	239	332
Fuel eff. (ℓ/100 tons)	34,93	31,74	40,59

**Table 5**  
Comparison of specific fuel consumption for Observation Periods 3 and 4

Tractor type	Observation period 3		
	Standard MF 375 + twin stack trailer	Articulated MF 375 + twin stack trailer	Articulated MF 390 + twin stack trailer
Total tons transported		1 798	2 096
Total fuel consumed (ℓ)		439	560
Fuel eff. (ℓ/100 tons)		24,42	26,72
Observation period 4			
Total tons transported	5 648	5 952	5 895
Total fuel consumed (ℓ)	1 749	1 802	1 827
Fuel eff. (ℓ/100 tons)	30,97	30,28	30,99

Accepting the fact that the one-way haulage distances and field conditions varied for each observation period, the results clearly indicate that in practice there is no difference in performance between the standard and articulated MF 375 haulage units. As expected, for the same given task, the MF 390 tractor developing 58 kW on average consumed more fuel than the MF 375 fitted with a 51 kW engine.

**Table 6**  
**Operating costs (R) 1990/91 season**

MF 375 standard haulage tractor											
	April	May	June	July	August	September	October	November	December	January	Total
Fuel	193	351	851	533	406	566	552	605	63	681	4 801
Spares	16	265	7	568	1 008		901	1 455	189	37	1 983
Lubricants		120	22		103	52	54	71	78	26	526
Labour			213	320	42	155	90	158	135	90	1 203
Tyres				5 953		254				29	6 236
<b>Total</b>	<b>209</b>	<b>736</b>	<b>1 093</b>	<b>7 374</b>	<b>1 559</b>	<b>1 027</b>	<b>1 597</b>	<b>2 289</b>	<b>465</b>	<b>863</b>	<b>17 212</b>

MF 375 articulated haulage tractor											
	April	May	June	July	August	September	October	November	December	January	Total
Fuel		305	843	496	592	478	504	933	138	136	4 425
Spares		218	114	205		1 470	561	238	126	269	3 201
Lubricants			23	36		70	48	45	57	14	293
Labour		60	40	380	720	203	257	45			1 705
Tyres					5 823						5 823
<b>Total</b>	<b>0</b>	<b>583</b>	<b>1 020</b>	<b>1 117</b>	<b>7 135</b>	<b>2 221</b>	<b>1 370</b>	<b>1 261</b>	<b>321</b>	<b>419</b>	<b>15 447</b>

*Seasonal haulage costs*

The comparative operational costs for the two haulage vehicles during the 1989/90 season were somewhat obscured, because of the development work carried out on both units during the first full season. However, the performance of the two haulage units was monitored during the 1990/91 season and these results are given in Tables 6 and 7.

**Table 7**  
**Summary of season costs - 1990/91**

Vehicle type	Total fuel (litres)	Total operating costs (R)	Rand per litre
MF 375 Standard	6 013	17 212	2.86
MF 375 articulated	5 433	15 447	2.84

Although it is too early to make a final cost comparison of the two haulage units, which have operated for two and a half seasons only, the articulated haulage unit's operational cost to date are marginally lower than that of the standard haulage unit.

In time, it will be interesting to assess the saving in costs that would normally have been incurred on the repair and maintenance of king pins, pivot pins, steering boxes and punctures usually associated with conventional front steering axle haulage units.

**Conclusions**

The articulated tractor haulage unit has performed extremely well to date and some of the original objectives have

been accomplished. Not only has the number of haulage vehicles been reduced from five to four units, but average daily operating hours have been reduced to an acceptable level. Furthermore, the average fuel efficiency of 32 l/100 t of the current haulage operation shows a marked improvement over the 48 l/100 t used previously.

Although the difference in performance between the articulated and standard infield haulage units appears to be small, the final operating costs at the end of the expected life of the machines should prove interesting. The articulated haulage unit has shown that it is more effective under poor infield operating conditions, and is more operator-friendly as far as steering and comfort are concerned than the standard front steer haulage combination. It is felt, however that the articulated haulage unit is a viable proposition only for large sugarcane estates, because of the units limited off-season use.

The enthusiasm of the Cornubia Estate staff regarding the performance of the articulated haulage unit has led to neighbouring estates acquiring similar units. However, based on the experience gained with the 51 kW articulated haulage vehicle, 58 kW prime movers were chosen because of their more robust construction and generally superior performance.

**Acknowledgements**

Thanks are due to Natal Mechanised Farming (Pty) Ltd and T.I. Trailers (Pty) Ltd for their co-operation and contributions towards this valuable and most interesting project.