

FAREWELL TO FILTERS: THE RECYCLE OF CLARIFIER MUD TO THE DIFFUSER

DM MEADOWS¹, GT SCHUMANN¹ AND C SOJI²

¹*Tongaat-Hulett Sugar Ltd, Private Bag 3, Glenashley, 4022*

²*Tongaat-Hulett Sugar Ltd, PO Box 5, Maidstone, 4380*

Abstract

A cane diffuser is a fairly efficient filter, retaining within the bagasse bed much of the suspended material that would otherwise pass into the draft juice. It was decided to investigate the possibility of utilising this filtration capability further by recycling the mud (underflow) from the juice clarification station to the diffuser(s). The solids in the mud would then be carried in the bagasse to the boilers, where the combustible portion would be incinerated and non-combustible material would become boiler ash.

Maidstone mill was selected for a trial, as it has two diffusers and uses two clarifiers, facilitating comparison. A two-week trial was carried out in which the mud from one of the clarifiers was recycled on to the bed of one of the diffusers. This was followed by a one-week trial in which all of the clarifier mud was recycled to one of the diffusers, during which period no filtercake was produced by the factory. Results of these trials are discussed, and effects on diffuser operation, extraction, sucrose degradation, and ash levels in bagasse and juice are examined.

The practice of mud recycle offers the possibility of eliminating completely the need for a filtration station and its ancillaries (including bagacillo systems and filtercake conveying) in an ordinary raw sugar diffuser factory.

Introduction

The current focus in the South African sugar industry is the need to minimise costs in order to remain internationally competitive. Earlier drives to maximise processing efficiencies and recoveries have borne fruit, placing the industry in an enviable position with respect to its technological standards. However, it is now necessary to redirect primary efforts towards reducing both fixed and operating costs at our factories.

It was in this light that Tongaat-Hulett sugar decided to investigate the technical feasibility of a processing option that has existed since the installation of the first cane diffuser in the industry, some 25 years ago. This is the option of utilising the filtration capability of the prepared cane bed in a diffuser to perform the filtration of muds (underflow) from the juice clarification station, a duty currently performed (without exception in South Africa) by rotary vacuum filters.

A cane diffuser is a fairly efficient filter, retaining within the bed much of the suspended material that would otherwise pass into the draft juice. This is shown by the much lower

suspended solids % mixed juice levels encountered at diffuser factories than at milling factories, as well as the fact that most diffuser factories do not find it necessary to use DSM screens to screen the juice. Should the clarifier muds be returned to the diffuser, the solids in the mud would therefore be carried in the bagasse to the boilers, where the combustible portion would be incinerated and the non-combustible material would become boiler ash.

Previously published work in this area has attempted the entire clarification operation in the diffuser, obviating the need for either clarifiers or filters (Lamusse, 1980). Trials done in Hawaii and Venezuela encountered problems with colour formation when clarifying at high temperatures in the diffuser, and with post-precipitation when clarifying at lower temperatures in the diffuser. As a result, the practice was discontinued, but the replacement of the filtration step only was not attempted.

Trials

Trials were run during the 1997-98 season to assess the effects of this mud recycle on factory performance. Maidstone mill was selected for a trial, as it has two diffusers and uses two clarifiers, facilitating comparison. A two-week trial (beginning 8/9/97) was carried out in which the mud from one of the clarifiers was recycled on to the bed of one of the diffusers. This was followed by a one-week trial (beginning 9/12/97) in which all of the clarifier mud was recycled to one of the diffusers, during which period no filtercake was produced by the factory.

Figure 1 is a flow diagram of the mud recycle arrangement. Mud was withdrawn from the four mud oftakes of the Dorr type clarifier as normal, into a collection gutter. The mud then passed down a single pipe into the suction of the clarifier liquidation centrifugal pump. This pumped the mud to a small redundant juice scale, which was refurbished for the purpose. This included modifying the scale tank to minimise mud holdup and eliminate potential dead zones, to prevent degradation of the mud. A centrifugal pump was then installed to pump the mud from the scale to the new (1994) Tongaat-Hulett 300 TCH capacity diffuser.

Careful consideration was given to the method and position of application of the mud to the diffuser bed. Three criteria applied:

- To prevent interference with extraction through the counter-current leaching process, the mud should be added

at the point where the juice in the diffuser is at the same brix as the mud. By this criterion, the mud should be added as close to the draft juice end as possible.

- To prevent blinding of the bed, the mud should be added where the bed is not too heavily compacted, such as near a set of lifting screws.
- To provide good filtration, the mud should be added where the bed is well established.

The best compromise was to add the mud immediately before the first set of lifting screws (positioned above the third juice tray from the cane feed end). This was done by pumping the mud into the suction of the stage pump delivering juice to the

spray positioned before this set of screws. In this way no holdup of mud in the juice tray was possible and the use of the juice spray ensured even distribution of mud across the bed.

As mud recycle would obviously interfere with Mill Balance, it was agreed in consultation with Cane Testing Services that an average Pol Factor (using data from the weeks before and after the trials) would be applied to Direct Analysis of Cane for Cane Payment purposes. Should the mud recycle process be implemented permanently, it would be necessary to assize the mud scale and institute an agreed mud sampling and analysis programme, to incorporate this data into the Mill Balance.

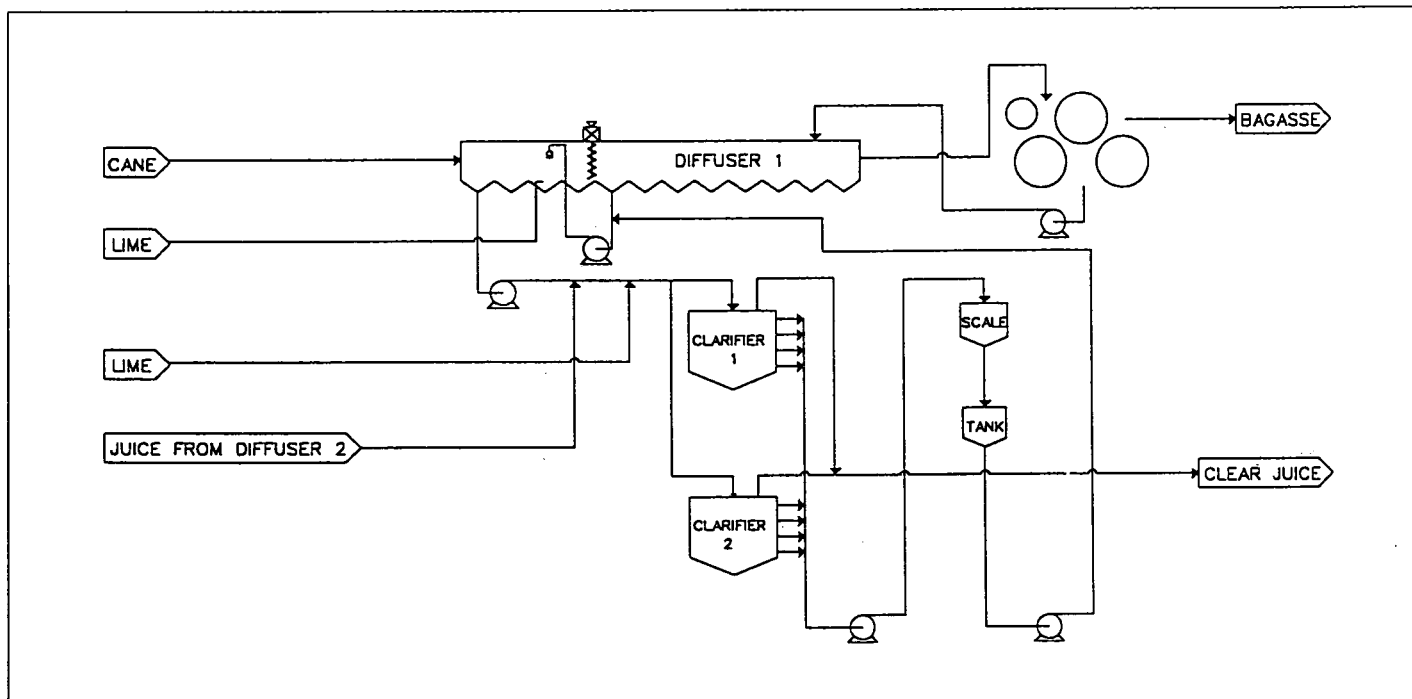

Figure 1: Process flow diagram of mud recycle.

Data collection, sampling and analysis

Data collection, sampling and analysis was carried out for three weeks prior to Trial 1 and one week after, and for one week prior to Trial 2 and one week after.

The following data were recorded during each trial:

- The temperature of the mud entering the stage pump suction was recorded twice per shift.
- The levels of juice in the bed at stages 2, 5 and 7 were recorded twice per shift.
- The positions of the adjustable juice sprays were recorded twice per shift.
- Any incidence of flooding in the diffuser was logged.

The following samples were taken and analyses done:

- A bagasse sample was taken for ash analysis once per hour and composited per shift.

- A draft juice sample was taken for suspended solids analysis once per shift. During trial 2, the suspended material was then ashed to obtain ash % mixed juice data.
- A mud sample was taken for pol and brix analysis twice per shift in Trial 1 and once per shift in Trial 2. Pol and brix were analysed immediately while an aliquot was stored in the refrigerator and analysed for bagacillo % mud and mud solids during the day shift. After drying, the bagacillo and mud solids were recombined and then ashed for ash % mud.
- A draft juice sample was taken from each diffuser for lactic acid analysis once per shift.

All the above analyses (except ash % mud) were performed according to the procedure in the SASTA Laboratory Manual for South African Sugar Factories.

In addition to the above, the routine mill and CTS analyses were used to compare values for ash % cane, extraction and MJ-DAC purities before, during and after the trials.

Results and discussion

General

Table 1 is a summary of results from the two trials, and Table 2 contains ash data for the two trials. The following problems were encountered during Trial 1:

- The trial coincided with two weeks of high levels of ash % cane (a 41% increase on the average for the weeks before and after), making ash level and diffuser performance comparisons difficult.
- The clarifier liquidation pump was oversized for its duty as a mud pump. It was thus run intermittently, sometimes being left off for hours at a time. This practice was unfortunately only discovered after the trials, and obviously had a negative effect on both mud deterioration (as the purity results indicate) and on the reliability of ash % bagasse

data (as the sample may or may not have been taken during pumping of mud).

The above shortcomings formed part of the motivation for carrying out Trial 2, during which (fortunately) ash % cane was more typical.

Extraction and diffuser operation

Figure 2 presents graphically the extraction trends for the weeks before, during and after the two trials. Mud recycle had no observable effect on sucrose extraction. The weekly averages show a 0,2% drop during the recycle weeks in Trial 1 and a 0,1% rise during the recycle week in Trial 2. Neither of these changes is significant given the degree of scatter in the per-shift data (due to operational issues having a more direct effect on extraction).

Table 1. Summary of trial data.

Period	Factory TCH	Diffuser 1 TCH	Extraction (%)	Sus. solids % draft juice	Solids % mud	Mud rate (t/h)	DJ – mud purity (%)	DJ – DAC purity (%)
TRIAL 1								
3 weeks before	407	232	98,14	0,23	5,8		2,6	0,25
2 weeks before	377	237	98,35	0,24	5,1		4,5	0,43
1 week before	413	228	98,02	0,26	5,3		4,6	0,19
Trial week 1	382	216	97,98	0,27	6,5	4,1	8,4	0,76
Trial week 2	420	229	97,95	0,26	6,7	5,1	5,7	0,50
1 week after	388	223	98,10	0,28	5,5		6,1	0,47
% change	1	-3	-0,2	5	22		58	88
TRIAL 2								
Week before	412	255	97,50	0,25	4,5		8,0	1,22
Trial week	355	219	97,45	0,25	3,9	10,2	6,0	0,83
Week after	304	211	97,30	0,25	5,3		6,5	1,02
% change	-1	-6	0,1	6	-20		-17	-26

Notes: 1. Cane throughput is calculated as shift tonnage divided by hours and therefore neglects the effect of short stops.

2. % change figures are the difference between the figures during recycle and the 'normal' weeks, as a percentage of the 'normal' weeks' average.

Table 2. Ash balance data.

Period	Ash % cane	Ash in cane (t/h)	Ash % draft juice	Ash in draft juice	Ash % bagasse	Ash in bagasse (%)	'Corrected' ash % bagasse	Ash % mud	Ash in mud	Filtration efficiency	Balance error (%)
TRIAL 1											
3 weeks before	2,61	6,06			3,51	2,68	1,21				44
2 weeks before	1,97	4,67			3,49	2,69	3,03				24
1 week before	1,91	4,35			3,44	2,64	3,16				19
Trial week 1	2,84	6,13			5,27	3,88	2,49				23
Trial week 2	3,14	7,19			5,12	3,97	1,53				34
1 week after	2,01	4,48			3,77	2,90	3,18				15
% change	41	36			46	44	-24				
TRIAL 2											
Week before	1,70	4,33	0,10	0,28	2,97	2,83	3,19	2,34		0,91	10
Trial week	1,98	4,34	0,11	0,28	3,86	3,26	3,42	2,75	0,28	0,92	8
Week after	1,92	4,06	0,12	0,32	3,57	2,99	3,28	2,38		0,90	0
% change	9	3	0	-7	18	12	6	17		2	

Notes: 1. % change figures are the difference between the figures during recycle and the 'normal' weeks, as a percentage of the 'normal' weeks' average.

2. Filtration efficiency is the efficiency of the diffuser bed in retaining incoming ash in the bagasse.

3. Balance error is the percentage non-closure of the ash mass balance around the diffuser.

4. For Trial 1 mass balance, ash in DJ and ash in mud are estimated from ash in bagasse and solids in mud, respectively.

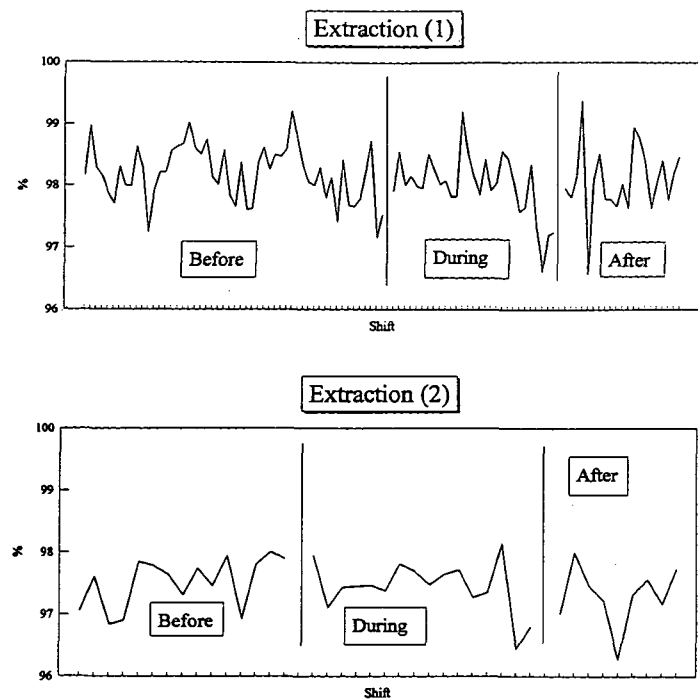

Figure 2. Extraction trends for Trials 1 and 2.

No significant differences in juice levels in the diffuser bed were seen as a result of mud addition to the bed. Similarly, it was not necessary to make any adjustments to the spray positions, suggesting no change in the percolation behaviour of the bed. Two incidences of flooding were recorded during the trials, but it was believed by mill staff that these had causes other than the mud addition.

Sucrose destruction

Figure 3 shows the mixed juice minus DAC purity data before, during and after the trials. Trial 1 weekly averages show an 88% increase during recycle, which is inexplicable as a consequence of the recycle. Trial 2 averages show a 26% drop during recycle, from an unusually high base level. Both changes are best attributed to random variation or operational issues, and neither trial showed the sort of serious drop in MJ-DAC purities that would suggest a significant increase in sucrose destruction in the diffuser.

A selection of the juice samples from both diffusers were analysed for lactic acid during Trial 1, to identify any trends, and this data is presented in Figure 4. There is a great deal of scatter in the data, but there is no evidence of a difference between the diffusers or of an increase in this sucrose degradation product during the trial (in fact, if anything, the trend is a declining one).

Mud quality

Mud temperatures taken at the diffuser during the trials averaged 78°C, with occasional excursions to lower values when pumping was resumed after a period of no pumping. If mud recycle is to be implemented on a permanent basis, effort should be made to sustain a higher mud temperature. The very high mixed juice minus mud purity difference data

reflects the serious problem that Maidstone was experiencing at the time with sucrose loss in mud, due to mud extraction difficulties (which have since been resolved). However, the second trial shows that mud recycle had no additional deleterious effect on mud (filtrate) purities. Trial 1 had a significant negative effect, due to the method used of intermittent mud pumping, which allowed mud buildup in the clarifier. Given Maidstone's mud deterioration problems at the time, the trials were a 'worst-case' test of the effect of mud addition on extraction and diffuser sucrose destruction.

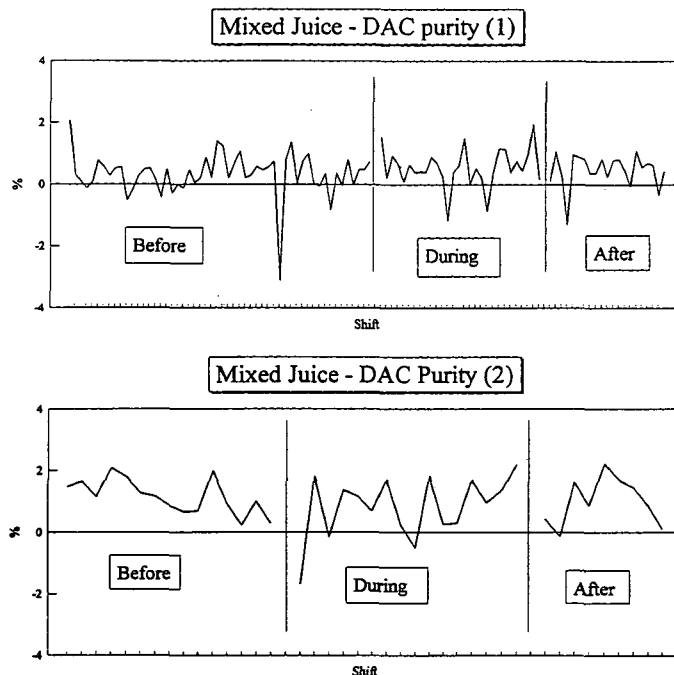

Figure 3. Draft juice minus DAC purity trends for Trials 1 and 2.

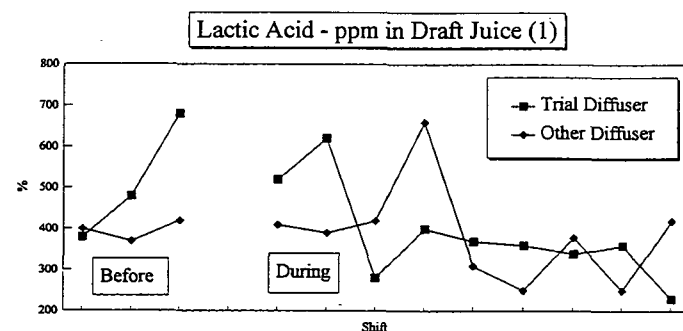

Figure 4. Lactic acid trends for Trial 1.

Ash in bagasse

The destination of ash is a key result in these trials, as a large increase in ash % bagasse would mean an unacceptable increase in boiler ash loading, with an associated increased danger of tube erosion. Ashing of the suspended solids in juice and in mud was introduced in the second trial to allow an ash balance around the diffuser to be performed. Figure 5 illustrates the balance using average data for the Trial 2 mud

recycle week. Lime addition rate was not measured, so usage is assumed as 0,28 kg CaO per ton cane, and it is assumed that all of the calcium precipitates as calcium phosphate (i.e. maximum ash contribution is assumed). Soluble ash % cane is assumed to be 0,5%. The balance calculations for Trial 1 in Table 2 were done using estimated values for ash in draft juice and ash in mud.

Three problems are apparent:

- The balance does not close, inputs exceeding outputs in eight of the nine weeks. Given the degree of scatter in the data, the degree of closure for Trial 2 is quite acceptable, but this is not the case for Trial 1, where inputs exceed outputs by between 15 and 44%. This may be due to an underestimation of the contribution of soluble ash % cane, and/or possible under-estimation of ash % bagasse. The fact that samples are taken for ash % cane eight times more frequently than for ash % bagasse may lead to ash peaks being picked up in the cane samples and missed in the bagasse.
- The conservative assumption made with respect to the ash contribution of liming appears to be an overestimation. The correct value is likely to be significantly lower, improving the closure of the ash balance.
- Ash in recycled mud data was available for one week only, during which tons ash in draft juice was equal to tons ash returning in mud. This indicates an underestimation in either ash % mud or tons mud per hour, as the returning mud should include ash in draft juice from the other diffuser as well as ash contributed by lime addition in clarification. An increase in ash in mud returned would, however, increase the ash balance errors.

The above concerns suggest that deductions regarding ash should be based on Trial 2 rather than Trial 1, and that relative rather than absolute data should be considered. Future work should also focus on tightening up this balance to corroborate conclusions drawn here.

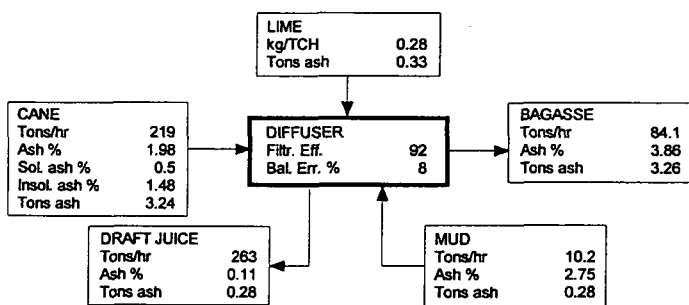

Figure 5. Ash mass balance for Trial 2.

Figure 6 plots the ash % bagasse data before, during and after the trials. However, since ash % cane values changed from week to week, comparison is difficult, as, for example, a 46% increase in ash % bagasse during Trial 1 has to be interpreted in the light of a 41% increase in ash % cane. For this reason, a

'corrected' ash % bagasse was calculated according to the relationship:

$$Ab_{corr} = Ab - e \cdot C / B \cdot (Ac - Ac_{std})$$

- where
- Ab_{corr} = Corrected ash % bagasse
 - Ab = Ash % bagasse
 - e = Diffuser filtration efficiency (explained later)
(assumed approximately equal to 0,9)
 - C = Cane throughput (t/hr)
 - B = Bagasse throughput (t/hr)
 - Ac = Ash % cane
 - Ac_{std} = 'Standard' ash % cane (selected as 1,8%).

This simple approximation attempts to correct for variations in ash % cane by deducting from the ash % bagasse data that contribution resulting from ash % cane levels above 1,8%, to allow comparison between weeks. The correction appears to have worked well on the trial 2 data, where the value for the trial week is 6% higher than the other weeks. The corrected data appear spurious for Trial 1, however, frequently going negative in the per-shift data, and showing a 24% decrease in the trial weeks. This provides further evidence to suggest that ash % bagasse data was underestimated in Trial 1 (as indicated by ash balance).

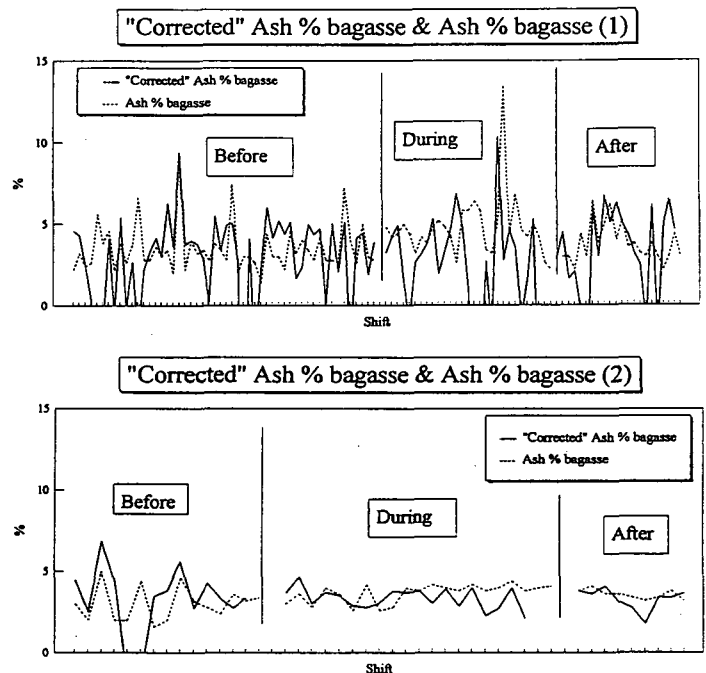

Figure 6. Ash in bagasse trends for Trials 1 and 2.

Given all of the above uncertainties, the additional ash load in bagasse due to mud recycle may be estimated as follows:

- The increase in corrected ash % bagasse during the trial week of trial 2, which was 6%.
- The tons ash in mud as a percentage of ash in bagasse, which, for Trial 2, was 9%. However, as mentioned above, tons ash in mud may be an underestimation.

- The percentage increase in ash % bagasse less the percentage increase in ash % cane for Trial 2. This was 12% minus 3%, giving 9%.
- The tons ash in draft juice (which would become ash in mud) as a percentage of ash in bagasse during non-recycle weeks, which, for Trial 2, averaged 10%. This is, of course, a slight underestimation of the effect of recycle as it neglects the ash contribution of lime addition in clarification.

To relate these figures to full-scale implementation, those from points 1, 2 and 3 above should be reduced by around 40%, as for Trial 2 all of the factory mud was being recycled to one diffuser (which was processing about 60% of the cane). While quantitative conclusions are difficult given the uncertainties in the above data, it may be said with some certainty that mud recycle increased ash in bagasse by 10% or less on existing levels. This level of increase should not have a deleterious effect on boiler operations or life.

Juice solids loading

Another possible concern with mud recycle would be that it increases the solids loading in the mixed juice to unacceptable levels. Comparison of the suspended solids % draft juice figures before, during and after the trials shows increases of 5% and 6% in this parameter as a result of mud recycle. However, these variations are probably well within the bounds of natural fluctuation in this parameter. Nevertheless, it is clear that the bulk of the recycled mud is not passing through into the draft juice.

An attempt was made to quantify the ash filtration efficiency of the diffuser bed. This filtration efficiency (*e*) was determined in the following way:

$$e = \text{tons ash in bagasse} / (\text{tons ash in bagasse} + \text{tons ash in juice}).$$

Table 2 presents the average values of 'e' per week for the Trial 2 data. An average value of 0,91 for the trial indicates that the diffuser bed is operating efficiently as a filter of ash, and that this efficiency is maintained when recycling mud. Assuming that the total suspended solids filtration efficiency of the diffuser bed is similar to that achieved on ash, the recycle of mud should therefore not result in any significant processing problems.

Smuts disposal

At most South African sugar mills, boiler smuts is disposed of by mixing it with filter cake from the filtration of clarifier mud and returning it to the fields as a fertiliser/soil conditioner. An unfortunate consequence of the implementation of mud recycle would be that an acceptable method of boiler smuts disposal would have to be found. This single factor is the current major obstacle to the full-scale implementation of mud recycle at Tongaat-Hulett sugar mills.

Conclusions

Through the implementation of two trials at Maidstone mill, the practicality of recycling clarifier mud to a diffuser has been demonstrated. The practice had no adverse effects on extraction or bed percolation and there was no evidence of increased sucrose destruction in the diffuser. Ash loading in bagasse to the boilers increased by no more than 10% on previous levels. Suspended solids levels in draft juice also increased by less than 10% and the filtration efficiency of the diffuser bed was found to be in excess of 90%. Mud recycle will be implemented for longer periods during the 1998 season to corroborate these findings, in particular the ash loading figures. Given a suitable method of boiler smuts disposal and acceptably accurate provisions to measure and analyse recycled mud (for cane payment purposes), the practice of mud recycle offers the immediate elimination of the filter station in a diffuser factory.

Acknowledgements

The authors wish to acknowledge the considerable contributions of the Maidstone mill Engineering, Operations and Laboratory staff as well as the TMD Laboratory staff in the execution of this work.

REFERENCES

- Lamuse, JP (1980). Practical aspects of cane diffusion. pp 197-253
In: *Sugar Technology Review* No. 7. Elsevier.