

DEVELOPMENT AND PROCESS DESIGN OF NEW MELTER STATION AT AL KHALEEJ SUGAR REFINERY

J AL GHURAIR and A S VAWDA

*Al Khaleej Sugar Refinery, Dubai
PO Box 17077, Dubai, UAE*

Abstract

The expansion of the Al Khaleej sugar refinery in Dubai necessitated the redesign of the melter station. This paper reports on the design and operation of a novel low temperature and low retention melter commissioned in April 2001. A simple mathematical model based on material and heat balances was developed to predict the performance of the melter. Several process flows were modified to achieve better process and energy efficiencies. Details of the stirrer design, recycle arrangement, screening and, most significantly, the use of two direct contact heaters in series, are discussed. Solutions to design and operating problems are also described.

Keywords: melter, stirrer, contact heater, sugar refinery

Introduction

To save electrical energy, the management of the Al Khaleej sugar refinery in Dubai took a decision to relocate the melting station outside the process building, closer to the raw sugar shed. Further objectives highlighted for this project were that any change from the current design philosophy must be mechanically robust and energy efficient. Two areas where mechanical efficiency was weak involved the recycle pump and the sugar scale. This paper is essentially a case study that attempts to show how the new melter system evolved. The paper is divided into four sections:

Period I: From factory commissioning in 1995 up to 1998. In this arrangement, the factory operated an affination system.

Period II: From 1998 up to and including 2001, major changes to the energy balance were implemented using pinch technology. Raw sugar at 96 polarisation was superseded by very high pol (VHP) as raw material, and the affination process was dispensed with.

Period III: From April 2001 to October 2001. This period saw the installation of a new four-chambered melter located outside the factory building, elimination of the sugar scale and the installation of two mass flow meters. Also, a second contact heater was installed for heating sweetwater, using the 25 kPa (a) vapour.

Period IV: This period began in October 2001, after period III was allowed to run for a few months. The main change here was the installation of a second contact heater for melt, using waste steam as the heat source.

Theory

Firstly, there is convention that refers to the sugar dissolver as the 'melter'. This paper will not attempt to put meaning to this nomenclature. In many processes it is necessary to dissolve a solid in a liquid. Most frequently it is to dissolve a solid in water. For the refinery to process raw sugar crystal it has first to be dissolved in water, as the subsequent purification steps are conducted in the liquid phase. There are two distinct phenomena that occur during the 'melting' of a sugar crystal. First, the solids must come into contact with water and then, as the liquid interacts with the crystals, dissolution occurs. The dissolution process is the exact opposite of the crystallisation process, and a brief review of the crystallisation process can be compared with the dissolution process.

The separation principle in the crystallisation process is insolubility. In the case of sugar, the solvent is evaporated until the solubility is exceeded, or the temperature is reduced until this effect is achieved. Sugar crystallisation is an exothermic process, i.e. the crystallisation process releases energy. Since all thermodynamic reactions are reversible, a re-examination of the dissolution of sugar is relevant. The 'separation' principle in the dissolution process is solubility. Here, the solute is diluted with the solvent until its insolubility is exceeded. The dissolution process absorbs energy. The question asked is, why is energy required for both processes when crystallisation is exothermic and dissolution is endothermic? The reason that crystallisation requires energy, is to drive off the solvent to maintain the driving force for crystallisation, i.e. supersaturation. However, the exothermic energy produced during the crystallisation process is insufficient to provide the energy required for evaporation of the solvent, and hence an external source of energy in the form of steam/vapour is required. In the case of crystallisation, the mass transfer is measured in $\text{kg}/\text{m}^3/\text{h}$ and is commonly described as the crystal deposition rate (CDR). Typical CDR figures are between 300-500 $\text{kg}/\text{m}^3/\text{h}$ in white sugar pans. In dissolution, the solubility of the sugar in the solvent (water) increases with increasing temperature, and the input of heat energy assists in increasing the rate of dissolution. The crystal dissolution rate has been measured to be in the range of 1500 to 3000 $\text{kg}/\text{m}^3/\text{h}$, under controlled conditions. Time is an important function in both crystallisation and dissolution. It has a considerable effect on the energy requirement, both in the form of heat and agitation. By extending the time period, input heat and agitator power can be decreased. Conversely, by increasing the input heat and agitator power, the dissolution time will decrease.

The agitated tank system

Most refineries have a 'melter' with either horizontal or vertical agitators. They operate at 70-85°C with energy supplied by direct contact with steam, usually medium pressure steam injected into the tank itself. Some factories have external contact heaters utilising evaporator vapour to supply the heat requirement. Others use surface heat exchangers when food safety regulations prevent the use of direct injection of steam into the sugar solution. The two phenomena mentioned earlier, dispersion and dissolution, are achieved by stirring and heating in an aqueous medium. The degree of agitation can be determined by the power delivered per volume (kW/m^3). In this case sugar and water are being mixed, so the focus is on internal recirculation. Agitators may be selected for shearing, using turbine blades, or for recirculation, using a marine type impeller, depending on the particular requirement. The turbine blade, while providing high shear, has the disadvantage that there is very little top-to-bottom mixing in the tank, and the product not in the immediate vicinity of the impeller sees very little agitation.

The marine type impeller, on the other hand, provides excellent top to bottom mixing, but sacrifices shear to do this. Other impeller designs provide a combination of shear and recirculation to achieve adequate shear throughout the mixing volume while ensuring that all material passes through the high shear zone. The use of impellers within draft tubes has also been successful in similar applications; commercial suppliers were nevertheless confident that acceptable performance could be achieved without draft tubes.

In the design of any melter, the two parameters to be considered are (i) saturation, and (ii) time.

Saturation

At lower brix, the dissolution process takes place quickly. However, any water that is added has to be re-evaporated using energy, and hence water addition is maintained at a process minimum. As illustrated earlier, the driving force for dissolving sugar is saturation that is a function of brix and temperature. The lower the brix and higher the temperature, the faster the dissolution. Conversely, when brix is high and temperature low, dissolution is poor. Sugar factory melters generally operate at between 65-70 brix and at temperatures between 70-85°C.

Time

As in crystallisation, where time is required for crystal growth, time is required for dissolution. A factor that came through clearly was the influence of crystal size for complete dissolution. Dissolution tests were conducted on sieved fractions under identical conditions, and the time taken for dissolution recorded. Under identical conditions, the larger the grain, the more time was required for dissolution. It can be seen that small grained sugar dissolves significantly quicker than coarse grain, and such a system will require less retention time. This is discussed in more detail in Appendix III (¹personal communication).

Retention time and recycle configuration

For continuous systems, the supplier recommended a mixing rate of about five turnovers per minute for syrup (i.e. one complete turnover in 12 seconds). This will allow a smaller vessel design volume and minimise the chance of bypassing. In this case, four vertical stirrers were selected to provide the well-mixed tanks in series, and each of the four tanks had about 4.5 turnovers, i.e. one complete turnover in 13.3 seconds. Volumetrically, this translates to 4900 m³/h per tank (¹personal communication). One turnover is the equivalent of taking all the fluid out of the tank and then putting it back in. Thus, 4.5 turnovers per minute means that the tank contents have been thoroughly mixed 4.5 times each minute. Theoretically one could use a pump, but this means that the entire contents of the tank would have to be circulated every 4.5 minutes. The retention time of the tank is the time the liquid and suspension stays in the tank before it leaves. There are two ways in which to look at retention when a recycle stream is involved (²personal communication): (i) recycle around the front end of the melter (Case 1), and (ii) recycle from the end to the front (Case 2). The common 'black box' approach to retention does not apply here.

The reasoning behind the selection of Case 2 was influenced by mechanical considerations, and was basically to ensure that the pump was supplied with a 'screened melt'. The refinery had suffered considerable downtime due to suction screen blockages in Period II. Because sugar is transported in bulk in ships, contaminants from previous shipments are unavoidable.

¹ T Clamp, Mixtec cc

² RCH Hoekstra

This operating requirement placed some constraint on the preferred design, and Case 2 was implemented. A discussion on the pros and cons of both cases can be found in Appendix I. The retention at 150 tons per hour in Case I is about 16 minutes, while in Case 2, the retention is 4 minutes. Due to this, the melter occasionally suffers from crystals leaving the fourth chamber while not fully dissolved.

Table 1. Retention time at different recycle rates.

Conventional configuration Case 1										
Melt rate	tons	150	150	150	150	150	150	150	150	150
Brix	%	65	65	65	65	65	65	65	65	65
Recycle	m ³ /h	0	100	200	300	400	500	600	700	800
Density	kg/m ³	1300	1300	1300	1300	1300	1300	1300	1300	1300
Volume of melter	m ³	60	60	60	60	60	60	60	60	60
Q net flow	m ³ /h	178	178	178	178	178	178	178	178	178
Retention	minutes	20.3	18.5	17.6	17.1	16.8	16.5	16.4	16.2	16.1
AKS configuration Case 2										
Melt rate	tons	150	150	150	150	150	150	150	150	150
Brix	%	65	65	65	65	65	65	65	65	65
Recycle	m ³ /h	0	100	200	300	400	500	600	700	800
Density	kg/m ³	1300	1300	1300	1300	1300	1300	1300	1300	1300
Volume of melter	m ³	60	60	60	60	60	60	60	60	60
Q net flow	m ³ /h	178	178	178	178	178	178	178	178	178
Retention	minutes	20.3	13.0	9.5	7.5	6.2	5.3	4.6	4.1	3.7

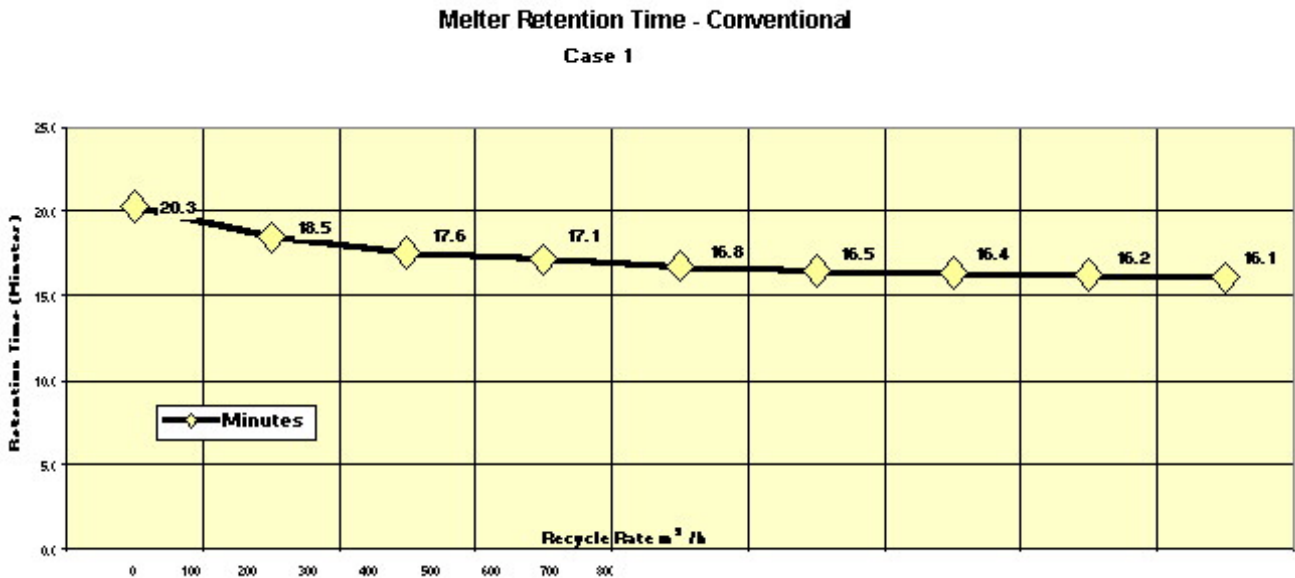

Figure 1. Relatively high retention time despite increasing the recycle rate.

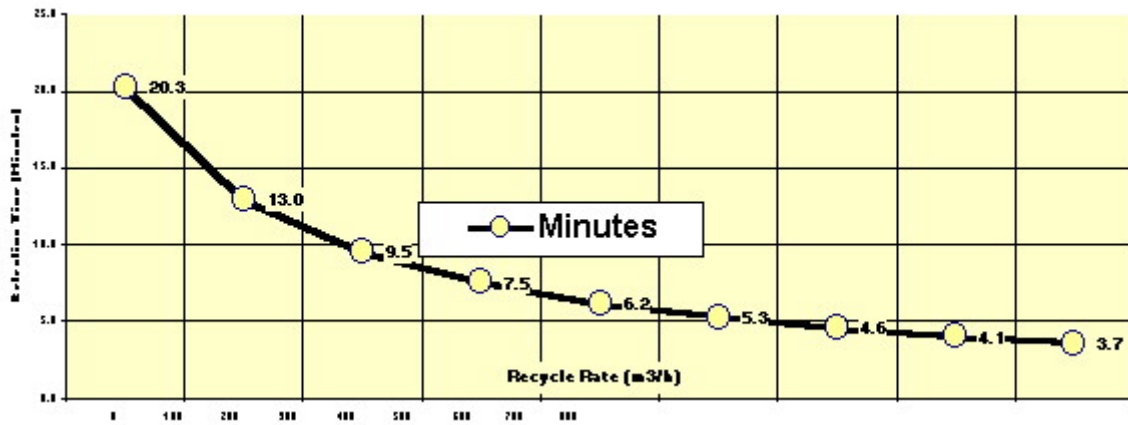

Figure 2. Sharp drop in retention time as the recycle rate increases.

Thermal energy and recycle configuration

The ideal condition for any heat exchanger is to be arranged in such a manner that the temperature difference (LMTD) is at its maximum. In this regard contact heat exchangers are no exception. Contact heaters also enjoy the benefit of the absence of a 'surface' to conduct the necessary heat. In Case 2, this condition is not optimum because, as the exit temperature increases, the delta T diminishes. For the condensation of, say, 5 tons of vapour at a melt rate of 150 tons per hour, the recycle volume demand increases significantly as the feed temperature increases. This is illustrated in Figure 3 and in Appendix IV. In the ideal case, slurry would be withdrawn from compartment number one, heated in a contact heater and returned to compartment number two.

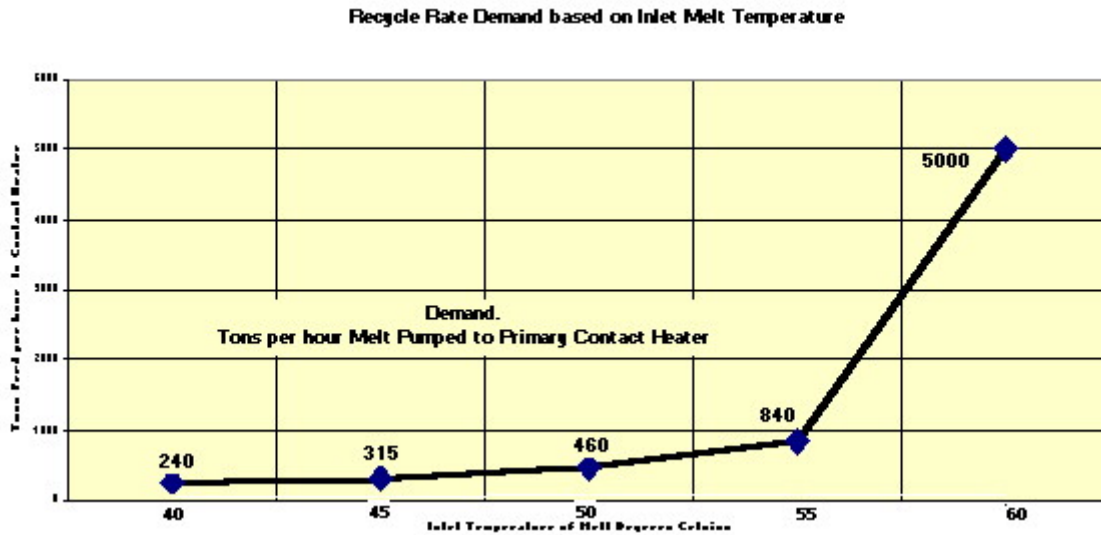

Figure 3. The influence of melter inlet temperature on recycle demand.

Savings in electrical energy

Period I

Al Khaleej sugar refinery was originally built to operate with power supplied from the local electricity grid. Since its inception in 1995, the refinery has been very conscious of reducing electrical energy costs and most factory improvement decisions were driven by this motive. The design in Period I catered for processing raw sugar at 96 pol.

This sugar quality justified the affination process, which is energy intensive. Comparisons of electrical installations can be seen in Table 2.

Table 2. Installed power during different periods.

	Period I	Period II	Period III	Period IV
Raw sugar conveyors x 3	75	75	71	71
Stirrers x 4			26	32
Raw sugar bin vibrators	8	8		
Batch sugar scale				
Lump crusher	4	4		
Screw conveyor	18.5	18.5		
Raw sugar mingler I	22	22		
Raw sugar mingler 2	18.5			
Affination pugmill	11			
Affination centrifuges 355 kW	135			
Melting trough	44	44		
Remelt liquor recirculation pump	55	55	75	200
Stirrers x 2	15	15		
Pump to remelt liquor screen	45			
Vibrating screen	4			
Carbonatation supply pump	37.5	37.5	75	75
Total kW	492.5	279	247	378
Total kW/ton sugar	4.92	2.79	2.47	2.4
Melt rate in tons per hour	100	100	100	155

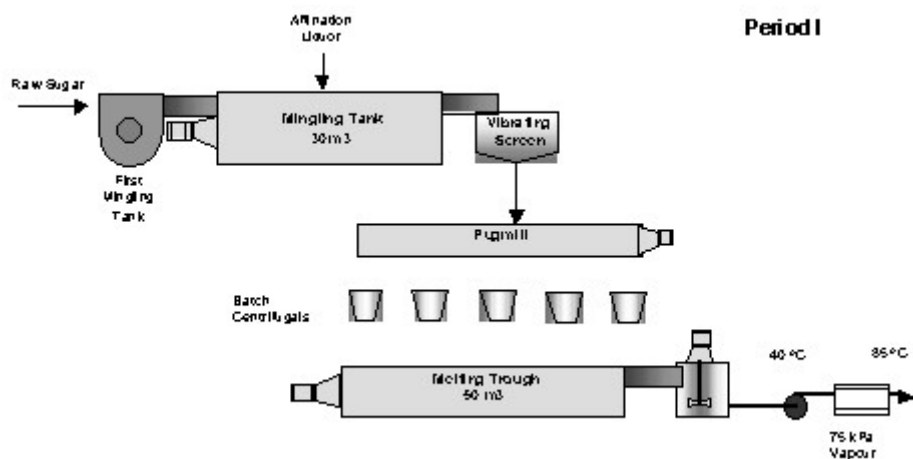

Figure 4. Original melter scheme incorporating the affination process.

Period II

The decision in 1998 to adopt VHP sugar as the raw material offered the opportunity to dispense with the affination process and enjoy the benefits of a scaled-down recovery house and reduced molasses losses. Simultaneously, energy consultants recommended the installation of a contact heater, for heating the melt using (flash) waste vapour II from the refinery double effect evaporator.

In this design, the sugar was slurried with the sweetwater and injected into the contact heater, referred to as the 'vapour melter'. The resultant melt was then heated in a shell and tube heater before being sent to the carbonatation station. All the electricity was purchased from the grid until commissioning of the new backpressure turbine in August 2001. This new turbine produces about 5.2 MWh, which is about two-thirds of the total requirement.

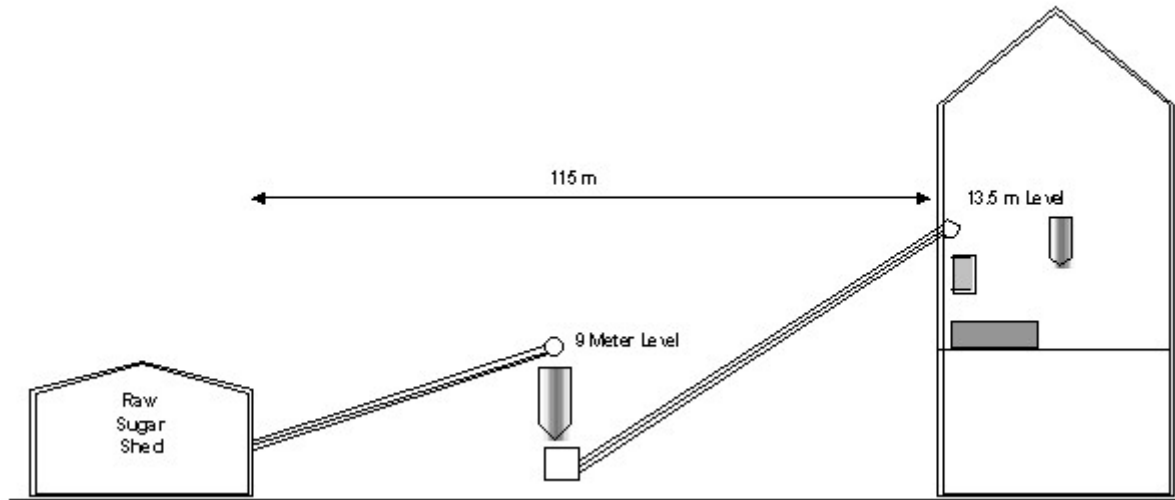

Figure 5. Arrangement of conveyors during Periods I and II.

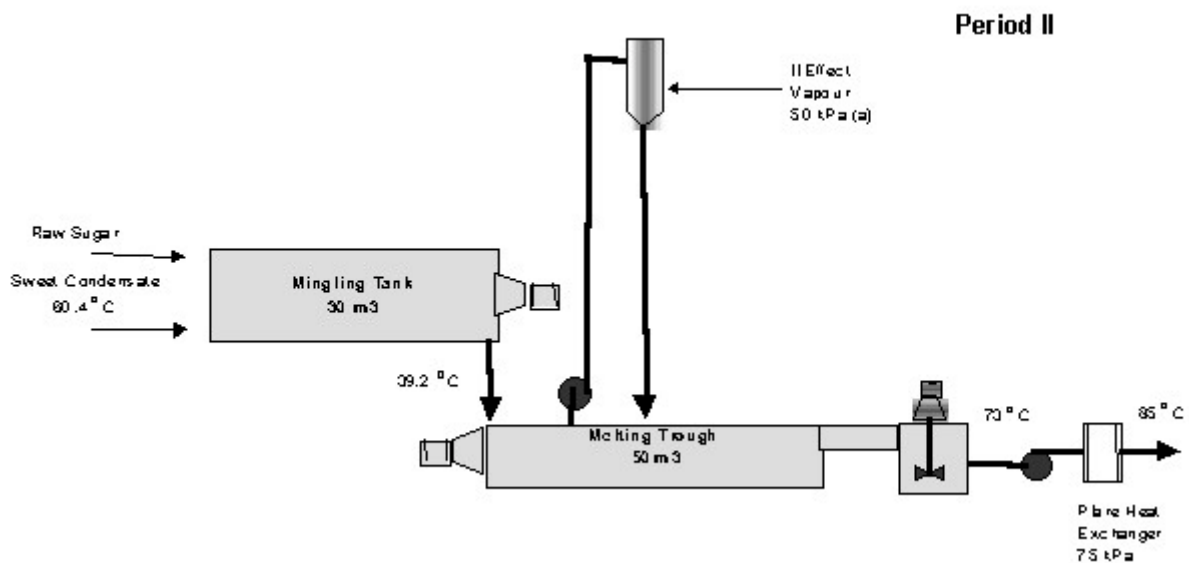

Figure 6. Configuration utilising external contact heater exchanger.

Period III

In 2001 a new idea was implemented, that involved the installation of a new four compartment agitated melter outside the refinery building in close proximity to the raw sugar shed. The sugar conveyance distance was reduced by 85 m. The sugar transfer height was also reduced by 4,5 m.

The heating configuration remained unchanged, by re-circulating some of the melt through the existing contact heater. In this design, the sugar scale was dispensed with and replaced by two mass flow meters.

Whereas in Period II, two sets of remelt pumps were utilised, this time only one set was installed. The retention time in the melter was sacrificed due to the flow configuration. The trade-off was due to the overall reliability of the recycle pump, which had previously often failed due to debris blocking the suction screen.

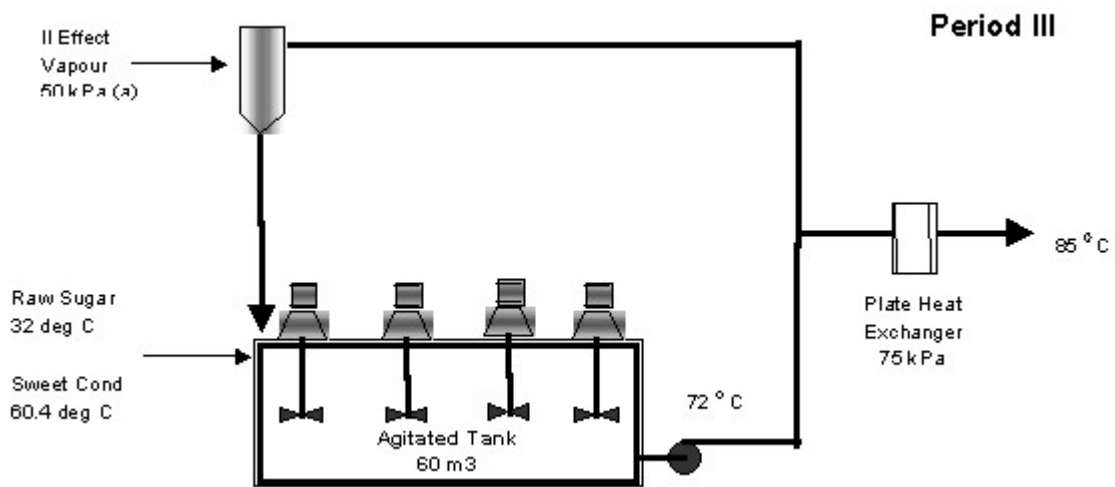

Figure 7. Configuration with new four-chambered agitated tank.

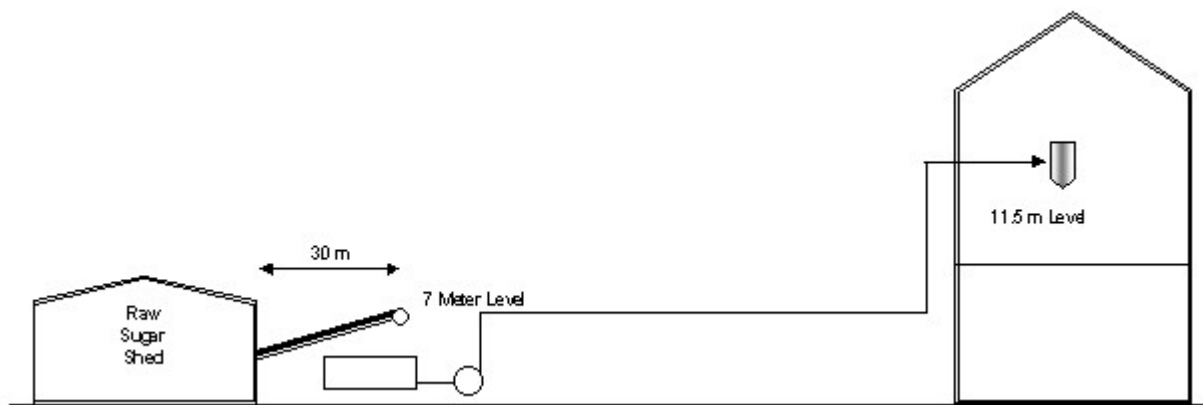

Figure 8. Arrangement of conveyors in Periods III and IV.

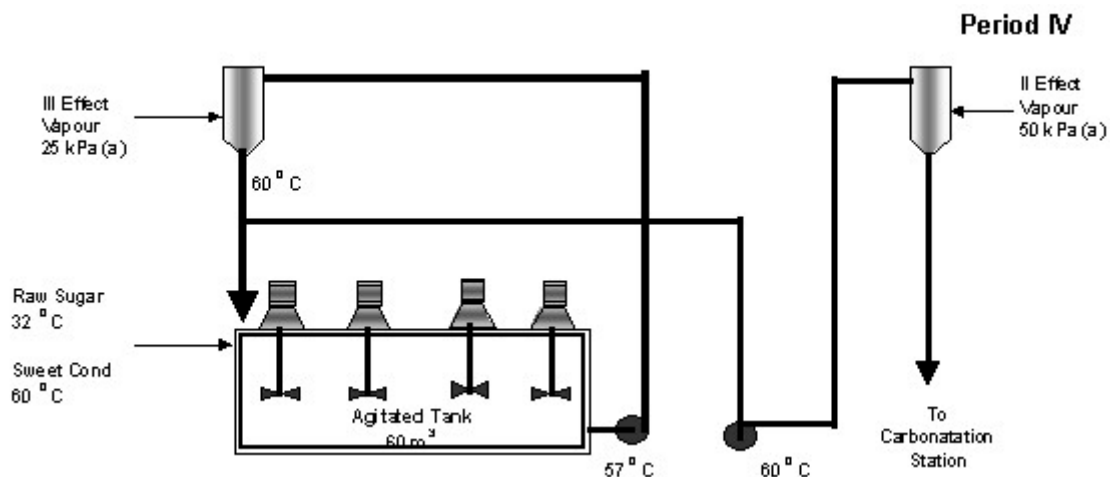

Figure 9. Configuration with two contact heaters in series.

Period IV

In this period the melt rate was increased from 2400 to 3700 tons per day. This time the motive was to reduce steam consumption by harvesting some of the 25 kPa (a) pan vapour that was wasted in the main central condenser.

Saving in thermal energy

Period I

This is the baseline where all heating was conducted by surface heat exchangers using 75 kPa (a) vapour.

Period II

At the commencement of this period, much of the factory's energy balance was reconfigured. The main change-over from the previous system was the elimination of the affination process and the adoption of VHP sugar as raw material. Heating was done in two stages. In the first stage, second effect vapour, consisting essentially of flash from effect II, was utilised to heat remelt liquor in a contact heater up to 73°C while in the second stage, a surface heater using 75 kPa (a) vapour raised the temperature to 85°C.

Period III

This configuration remained essentially the same, so there was no thermal energy saving. The adoption of an unconventional recycle scheme meant that 75 kPa (a) vapour was used more often than the 50 kPa (a) vapour used during Period II. Nevertheless, this did not have a negative effect on the steam balance. One of the problems experienced after the installation of a central surface condenser in June 2000, was that the sweet condensate temperature dropped as a result of sub-cooling in the condenser. The sweet condensate temperature follows the profile of the seawater that is used as a coolant in the surface condenser. The seawater temperature varied seasonally from 20-37°C, and resulted in lower melter operating temperatures and higher steam consumption.

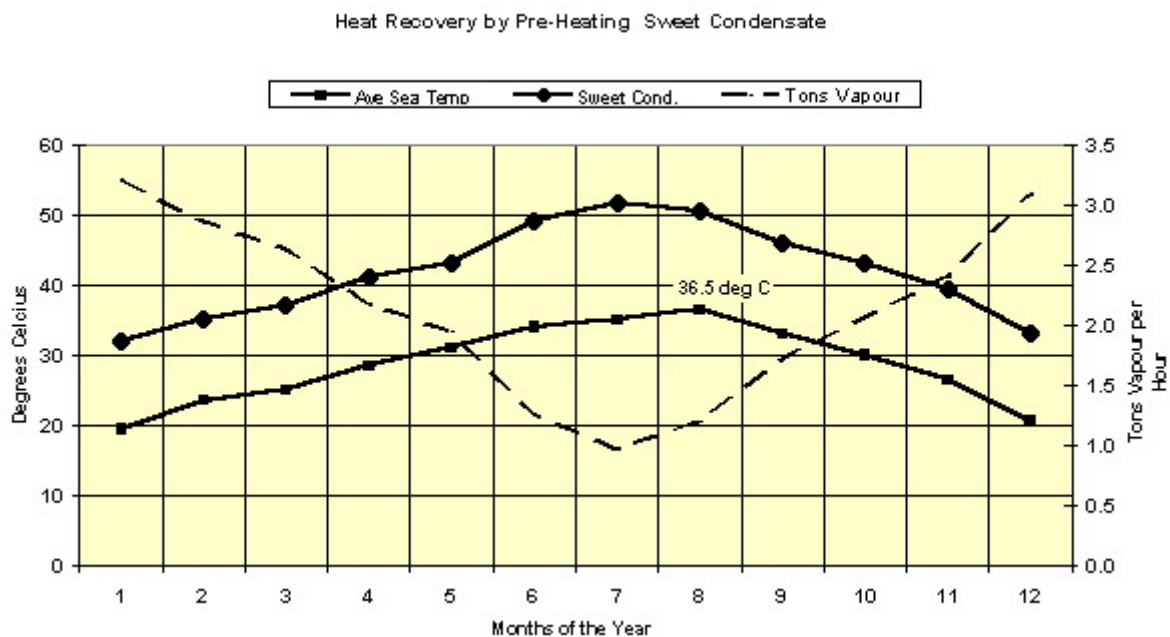

Figure 10. Heat recovery obtained by using 25 kPa (a) waste vapour.

Efforts to increase the temperature of the condensate by preventing sub-cooling resulted in poor vacuum performance. The 'cold' sweet condensate posed the potential problem of reduced melter operating temperatures, already low by any standard. To reheat the condensate, a pair of contact heaters was installed, again using waste 25 kPa (a) vapour to bring the temperature to 60-62°C. This resulted in a steam saving of between one and three tons per hour, depending on the cooling water temperature (seawater), as shown in Figure 10 and in Appendix V.

Period IV

This configuration saw the installation of a new contact heater using 25 kPa (a) pan 'vacuum' vapour to heat fresh melt. Normally, this vapour is condensed in the main central surface condenser and the latent heat is totally lost. The use of this 'waste' vapour to 'preheat' the remelt liquor resulted in a significant saving in steam consumption. About five tons per hour is consumed to raise the melt from 40 to 58°C.

Problems associated with each system

Period I

The original system was plagued with many problems, the main one being the constant blockages in the narrow gap plate heat exchangers. These were replaced with a shell and tube type, that proved more reliable. Another significant cause of downtime was the batch sugar scale. This problem persisted through Period II until the scales were eliminated in Period III. Period I was electricity and process intensive. Generally, the large quantity of process equipment in Period I was considered as 'not value adding to the process'. The retention time of sugar liquor in this system was about 100 minutes.

Period II

The elimination of the affination system significantly reduced the operating inventory and improved the mechanical reliability of the plant. One area that was still prone to frequent problems was the recycle pump, the screen of which was frequently blocked by debris arriving with the sugar. An irrigated vibrating screen, located between the mingler and the melting trough, provided some relief by removing most of this debris. Larger extraneous matter, like boulders and tramp iron, settled in the mingler and had to be removed during shutdown. On the process side, the retention time of 75 minutes was still deemed excessive. This was to be reduced in Period III.

Period III

The main change in Period III was the installation of the four chambered vertical agitator melter. Effectively similar in configuration to Period II, the mingler and melting trough were eliminated. The volumetric retention time was reduced significantly because of this. Due to problems with blockages in the recycle pump suction, the recycle configuration was changed to an unconventional design, i.e. Case 2. Details of this are discussed in Appendix 1.

Other initial problems were associated with sugar feed and the final screening:

- During commissioning of the vertical agitators, the power demanded by compartments three and four was higher than the first two compartments and also fluctuated. This was traced to the higher viscosity and lower temperature in compartments three and four. As the sugar dissolved and the liquor changed from 'slurry' to syrup, the viscosity increased. Compartments three and four agitator motors were changed from 5.5 to 7.5 kW. Installing vortex-breaking baffles as recommended by the agitator supplier eliminated the power fluctuations.

- New problems that manifested with regard to the vertical agitators were loss of efficiency when polypropylene fibres from bags wrapped around the shaft and propeller blades, thus impeding the compartment circulation. Periodic inspections adopted as standard procedure eliminated this problem.
- Melt screening problems. A vibrating screen with an aperture of 1000 microns was fitted to the overflow of the final compartment. The mechanical cleaning device failed frequently and was eventually replaced by a self-cleaning wedge wire screen, which works without vibration. Screen apertures smaller than 1000 micron were tested and were prone to blocking, resulting in frequent overflows, especially when undissolved crystals were carried over.

Period IV

An additional contact heater was installed utilizing waste heat. Throughput of the melter was increased by 50% and retention time reduced accordingly. The increase in throughput coupled with the reduction of operating temperature in the agitated tanks resulted in several problems that had to be solved:

- Due to the low temperatures, undissolved crystals often left the last chamber. This phenomenon was exacerbated by the unconventional recycle scheme
- Sugar overflowed during periods when the design melt rates were exceeded. As the original melter was designed for 100 tons per hour melt rate, the physical process of the sugar magmatising into the liquor was exceeded by the sheer flow, and the sugar backed up until dry sugar overflowed from the chamber. Removing the anti-vortex baffles eliminated this problem. Vortexing allowed dry sugar to penetrate the liquor. The stirrer motor of compartment one was replaced with a larger 7.5 kW unit, similar to those in compartments three and four.
- The barometric tailpipes of the contact heaters backed up and raw melt overflowed into the last effect evaporator, resulting in high insoluble matter in the refined sugar. The cause was traced to debris, mostly polypropylene fibres, blocking the inline mixer at the carbonation system. The inline mixer was eliminated and goose necks installed on the vapour inlets to the contact heaters. Elimination of the inline mixer was studied and no ill effects were measured in the carbonation process. It appears that the lime is suitably mixed in the 30 m pipe length between milk of lime injection and the first saturator.
- Control valve cavitation. The sweetwater flow to the melter is regulated as per brix requirement. Excessive vibration and noise at the control valve was experienced. This was traced to the fact that the sweetwater control valve was controlling the flow to a low-pressure downstream contact heater operating at 25 kPa (a). In the high velocity region within the valve, a low-pressure condition resulting from the intense turbulence, created localised cavitation and subsequently the implosion of vapor bubbles. To avoid any long term damage, the control valve was relocated right up against the body of the contact heater. The energy was now dissipated into a large volume and the vibration and accompanying noise disappeared.

Factory control

The removal of the sugar scale created an interesting scenario where the raw material 'solids' are measured in the liquid phase using a Corioliss type mass flow meter. This 150 mm meter produces three outputs, *viz.* flow, temperature and density. In order to use such a device, the challenge was to measure the sugars recycled in the A-sugar remelt and the sweetwater used for melting. The problem was solved by installing a second 80 mm Corioliss meter that measures the recycle sugar content and subtracts it from the input sugar mass flow rate. To calibrate these meters, special piping was set up to fill a road tanker with water or remelt. The tanker was then massed at the weighbridge.

Process control

Two items are of interest here; the melter brix control and the sugar feed control. With regard to the brix control, sweetwater is added primarily by measuring the power consumption of the motor driving the sugar feed conveyor belt. This was done as an alternative to installing a belt conveyor. Although it does not deliver a precise brix melt, the refinery is able to tolerate the brix fluctuation. A nuclear density meter (installed in the melter) monitors the brix and adjusts the ratio of the primary loop.

In the sugar supply shed, sugar is discharged onto the conveyor using knife gates. Operator involvement is required to set the flow of sugar manually as per the sugar stock lying in the shed and to instruct the front end loader to move any sugar to the feeding area. More details are found in Appendix II (³unpublished data).

Conclusion

The Al Khaleej sugar melter station has evolved into a reliable system with substantial plant inventory reduction, capacity extension and energy saving. One area that is under study is the optimisation of the recycle configuration.

Acknowledgements

The involvement of many departments at Al Khaleej Sugar Refinery is gratefully acknowledged. Without this support and teamwork, the project would not have been implemented as smoothly. Permission to publish this paper is also gratefully acknowledged.

³ S Ismail, Al Khaleej Sugar Refinery, Dubai, internal report, March 2003.

APPENDIX I

Study of the recycle configuration

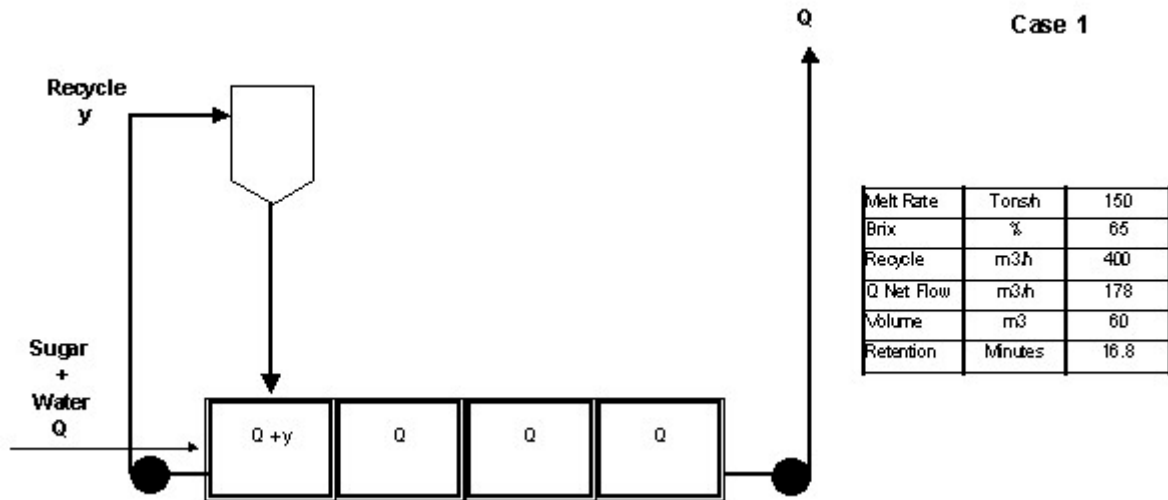

Figure 11. Case 1 recycle configuration.

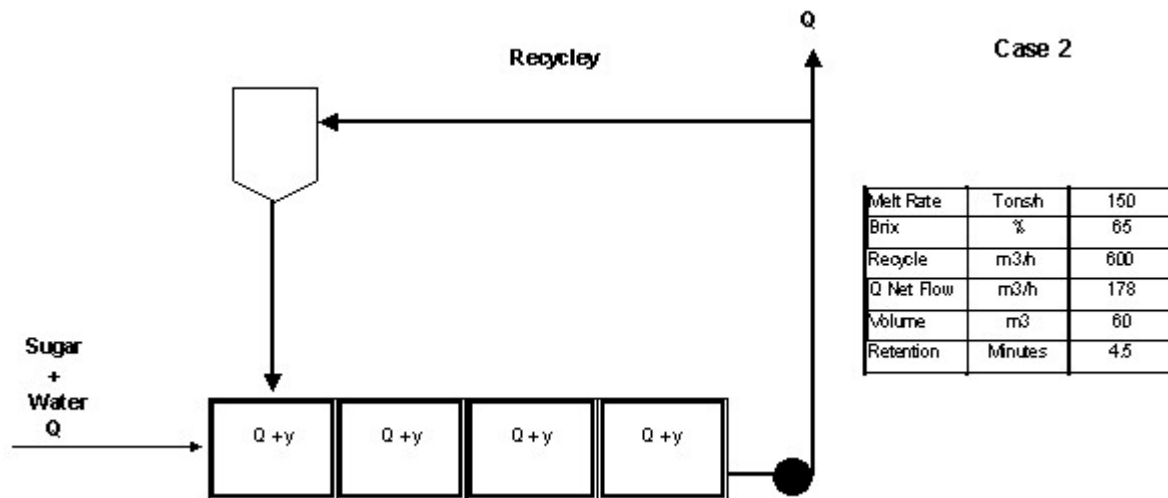

Figure 12. Case 2 recycle configuration.

Recycle configuration

In Figures 11 and 12, both recycle configurations are shown. The decision to implement Case 2 was due to mechanical efficiency concerns, i.e. blockages of suction screen. However, the process implications of the choice are discussed below.

The choice of Case 2 was basically to ensure that the pump was supplied with a 'screened melt'. The resultant design was therefore a compromise between process efficiency and mechanical reliability.

The melter must be imagined as a reverse acting continuous pan where the grains are successively melted, with the smaller grains dissolved first, hence the need for multiple stages. Each stage has a predefined retention time and appropriate dissolution performance.

Regarding the recycle pipe configuration, in both cases the return of the liquor from the vapour melter is back to the first cell. The issue was whether the off-take for the recycle through the vapour melter should be from the first cell (Case 1) or the last cell (Case 2).

Consider the remelter with its vapour melter recycle as a black box, with a given slurry input and given temperature and brix of the output. The vapour consumption and the mean residence time T must be the same for both cases. However, the spread in residence times will not be the same. Assume, for the moment, that the four stirred tank cells in series are a plug flow reactor. Further, assume that the residence time in the recycle loop is negligible. Let the production mass rate be Q , and the recycle rate $Q*y$. The recycle rate will probably be much higher than the production rate, i.e. $y > 1$.

Then, the throughput rate through the cells in Case 1 will be Q , and in Case 2, $Q*(1 + y)$. It follows that any crystal of sugar (or its molecules) for Case 1 will have a mean, a minimum and a maximum residence time of T in the plug flow reactor, as well as in the black box. For Case 2, the mean, minimum and maximum residence times will be $T/(1 + y)$ during one pass through the reactor. Bearing in mind that a quantity $Q*y$ of the output of the reactor and a fraction of $y/(y+1)$ of the sugar molecules is recycled, the mean residence time of the black box is T , as reasoned above. It follows that, for Case 2, the minimum residence time will be $T/(1 + y)$, the mean T . What is important in remelters is the minimum residence time because, if insufficient, it will not allow the larger crystals to dissolve.

APPENDIX II

Process control of the new melter

Melter brix control

By measuring the power consumption of the sugar feed conveyor, an estimate of the sugar feed rate is obtained. The output of this measurement is used to proportionally add sweetwater by ratio control. Initially, using brix analysis from the laboratory, this ratio is adjusted to achieve the desired brix. A nuclear density meter installed in the melter automatically 'fine-tunes' the ratio controller set point to achieve the required final brix exiting the fourth compartment.

Sugar feed control

Raw sugar is stored in the main sugar shed. The shed consists of 34 feeding gates distributed in a 'Y' shape. The feeding gates are equipped with manual gates and cylinder actuated knife gates. In order to control the feed of sugar, a Siemens S7 200 PLC with a touch screen has been installed locally inside the tunnel. According to the sugar distribution inside the store, the operator decides on the percentage to which the gates will be opened. He selects the required gates from the panel and switches to auto mode. The operator selects either H1 (high level) or H2 (ideal operating level) from the screen so that the gates will open and close accordingly.

Throughput (melting rate) control

The 150 mm Corioliss mass flow meter is the primary measurement and control element. The net sugar flow rate is computed by continuously deducting any recycle sugar flow rate measured by the 80 mm mass flow meter. The ‘recycle’ sugar consists of sweetwater from carbonation, desweetening water from the activated carbon columns and A-sugar remelt. In order to control the forward flow rate, the 150 mm mass flow meter sends a signal to the variable speed pumps and to the control valve at the inlet of the second contact heater.

The level in the melter pump suction chamber, identified as chamber 5, determines the rate of forward flow. If this level continues to drop due to sugar feeding problems, the set point for melting is cut back to avoid stop-start conditions.

APPENDIX III

Dissolution rates

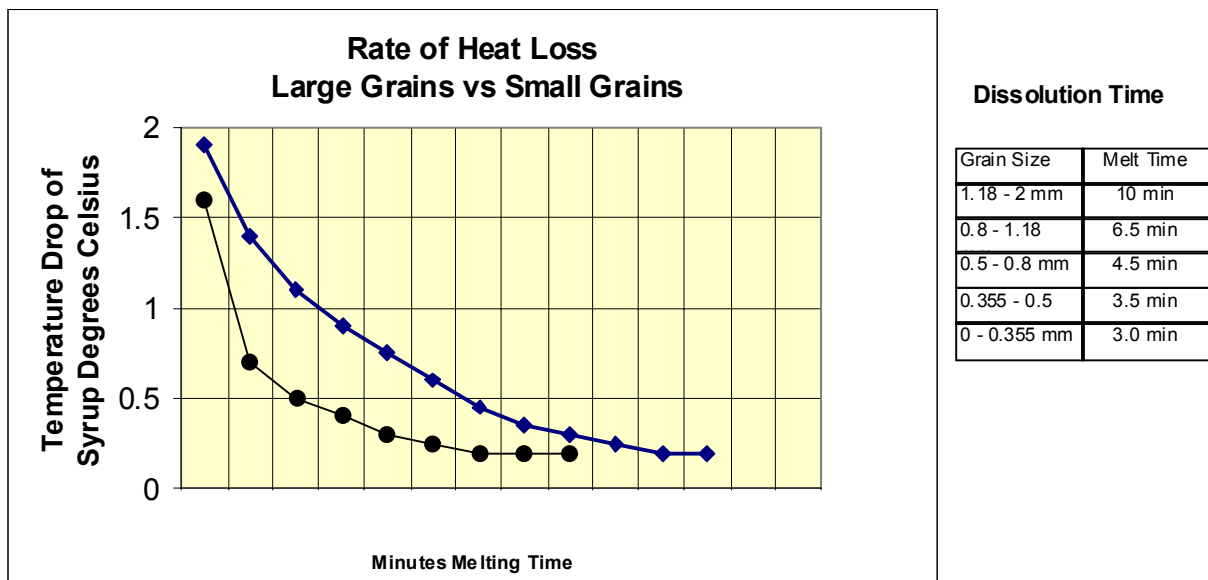

Figure 13. Heat loss during dissolution test.

Crystal size has been found to have a significant influence on the time required for dissolution. To investigate this, dissolution tests were conducted on sieved fractions under identical conditions, and the time taken for dissolution recorded. The dissolution was monitored by the naked eye and the final temperature was used to monitor completion of the dissolution process. For grain size above 1.18 mm, the time required was 10 minutes. For 0.8-1.18 mm, the dissolution time was 6.5 minutes. The curve of the rate of temperature drop had a similar shape for the dissolution of all grain sizes, but was steeper for fine grain, indicating quicker dissolution. It was seen that small grained sugar dissolves significantly faster than coarse grain and will require less retention time and energy.

APPENDIX IV

Direct contact heater

Liquor rate	Q	t/h	240	315	460	840	5000
Liquor brix	Bx	°	65	65	65	65	65
Liquor density	D	kg/m ³	1300	1300	1300	1300	1300
Liquor temperature - in	Ti	°C	40	45	50	55	60
Liquor temperature - out	To	°C	61	61	61	61	61
Vapour pressure	P	kPa (a)	25	25	25	25	25
Energy balance							
Specific heat		kJ/kg.K	2.55	2.55	2.55	2.55	2.55
Energy transferred		kW	3576	3576	3590	3576	3547
Saturation temperature		°C	65.3	65.3	65.3	65.3	65.3
Enthalpy available		kJ/kg	2363	2363	2363	2363	2363
Vapour flow		t/hr	5.45	5.45	5.47	5.45	5.40
Vapour density		kg/m ³	0.16	0.16	0.16	0.16	0.16
Vapour volume flow		m ³ /s	9.38	9.38	9.42	9.38	9.31
Liquor exit brix		Brix %	63.6	63.9	64.2	64.6	64.9

APPENDIX V

Heat recovery obtained by using 25 kPa (a) waste vapour

Recorded seawater temperatures		Sweet cond.	Tons vapour
Month	Ave sea temp		
January	19.5	32.0	3.20
February	23.5	35.0	2.86
March	25.0	37.0	2.63
April	28.5	41.0	2.17
Mat	31.0	43.0	1.94
June	34.0	49.0	1.26
July	35.0	51.5	0.97
August	36.5	50.5	1.20
September	33.0	46.0	1.71
October	30.0	43.0	2.06
November	26.5	39.5	2.40
December	20.5	33.0	3.09

Sweetwater	t/h	65	65	65	65	65	65	65	65	65	65	65	65
Brix	°	1	1	1	1	1	1	1	1	1	1	1	1
Density	kg/m ³	1000	1000	1000	1000	1000	1000	1000	1000	1000	1000	1000	1000
temp. in	°C	32.0	35.0	37.0	41.0	43.0	49.0	51.5	49.5	45.0	42.0	39.0	33.0
temp. out	°C	60	60	60	60	60	60	60	60	60	60	60	60
Vapour pressure	kPa (a)	25	25	25	25	25	25	25	25	25	25	25	25

Energy balance													
Specific heat	kJ/kg.K	4.16	4.16	4.16	4.16	4.16	4.16	4.16	4.16	4.16	4.16	4.16	4.16
Energy transferred	kW	2104	1879	1728	1428	1277	827	639	789	1127	1353	1578	2029
Saturation temp.	°C	65.3	65.3	65.3	65.3	65.3	65.3	65.3	65.3	65.3	65.3	65.3	65.3
Enthalpy available	kJ/kg	2367	2367	2367	2367	2367	2367	2367	2367	2367	2367	2367	2367
Vapour flow	t/h	3.20	2.86	2.63	2.17	1.94	1.26	0.97	1.20	1.71	2.06	2.40	3.09